



PRODUCE

COLLECTION

 **DISPLAYS**
Cayuga





DEPARTMENT: PRODUCE

The produce department is the single greatest determiner of customer loyalty. More than just showcasing fresh product, the produce area needs to have a fresh overall energy too, with plentiful displays and great range of product.

Cayuga Displays has an extensive line of display possibilities to highlight the produce itself, as well as to cross-merchandise related products, like dried fruits, sauces and nuts. We offer great options for getting more refrigeration on your floor in order to build your customers' shopping experiences and get more product noticed.

And when you work with Cayuga Displays, you can always be confident we'll help you to select the right product and options, so that you have the food presentation that is certain to elevate your customers' experience and enhance your brand - beautifully..

"Longos is pleased to support Cayuga Displays. Your team's quick service/turnaround for projects has helped us with our millwork for bakery and floral in past projects. More recently your team has come up with some cost effective refrigeration solutions for our bakery and produce."

Paul Collette,
Longo's Support Center
Project Manager Real Estate
and Construction

Table of Contents

Multi-Tier Island	
Multi-Tier Double Sided Table - Flat Deck	6
Multi-Tier Double Sided Table - Angled Deck	7
End Cap Table - Small Depth	8
End Cap Table - Large Depth	9
Banana Riser	10
Multi-Tier Table	
Double Sided Multi-Tier Table	12
Single Sided Multi-Tier Table	13
Island Produce Tables	
Table With Open	15
Base Storage	15
End Cap Table With Open Base Storage	16
Market Bin	
Market Bin	18
Market Bin w/ Base Merchandising	19
Market Ice Bin	20
Market Ice Bin w/ Base Merchandising	21
Wing Table - 3 Open Sides	22
Closed Wing Table	23
Narrow Multi-Shelf Table	24
Accessories	
Bag Holder	26
Produce Tray	27
Produce Tray w/Lip	28
Anti-Bruise Foam Mattnng - Roll	29
Clamp on Sign Frame	30
Finishes	
Laminate	31
Painted Metal	33
Wood Stains	34
How to Order	35

MULTI-TIER ISLAND REFER TO PAGES 6 - 10



Finish: Select Cherry

13' 5" L Flat Deck Single Level shown
(refer to pages 6 & 8)



Finish: Danish Walnut

7' 10 1/2" L Flat Deck Multit-Level shown
(refer to pages 6 & 8)



Finish: Oiled Cherry

13' 5" L Angled Deck Single Level shown
(refer to pages 7 & 8)



Finish: Weathered Wood

7' 10 1/2" L Angled Deck Multit-Level shown
(refer to pages 7 & 8)



Finish: Natural Maple

17' 11" L Angled Deck Multit-Level shown
(refer to pages 7 - 10)

Applications

- The multi-tier island tables are designed to be easily installed into an island setup, either with or without the upper shelf
- Both upper and lower table decks have sign track for clearly visible price tags
- Heavy duty locking casters, corner caps and bumper
- Centre tables come in either angled deck or flat deck

MULTI-TIER DOUBLE SIDED TABLE

FLAT DECK



MODEL	DESCRIPTION	LENGTH	DEPTH	HEIGHT
TBFD-022-01B	Multi-Tier Double Sided Flat Deck - 48"	47 1/2"	79"	52"
TBFD-022-01C	Double Sided Flat Deck -48"	47 1/2"	79"	32"
SHCM-014-14.25-29.50	Mounted Shelf	29 1/2"	14 1/4"	3"

FEATURES:

- Birch/maple plywood, MDF and solid maple construction
- 3 Track sign holder
- Locking casters
- 1 1/2" ABS bumper

OPTIONS:

- Mounted side shelf
- Refer to Wood Stains Finishes

Note: Information and specifications may change due to engineering improvements.

Optional Mounted Shelf

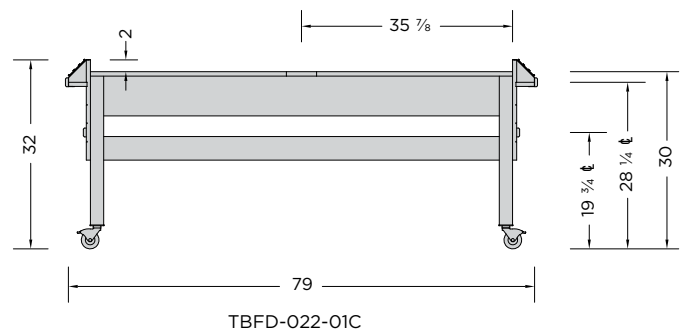
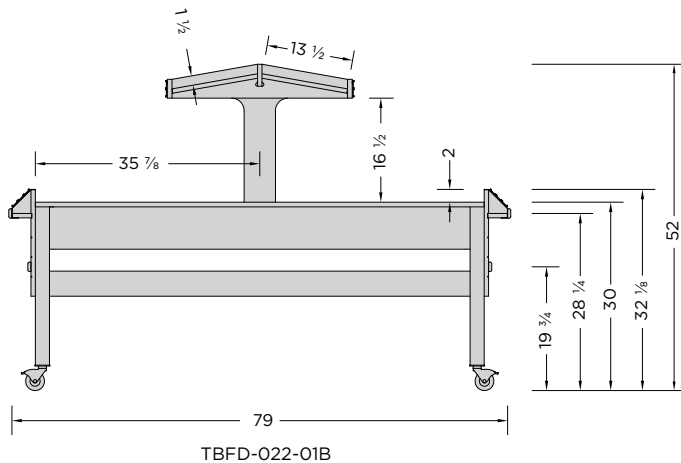
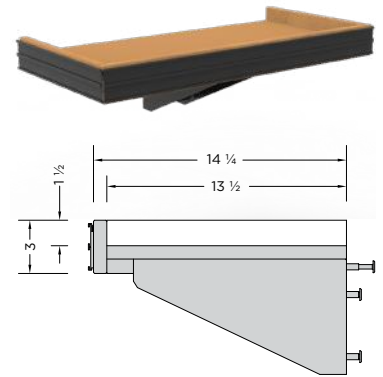
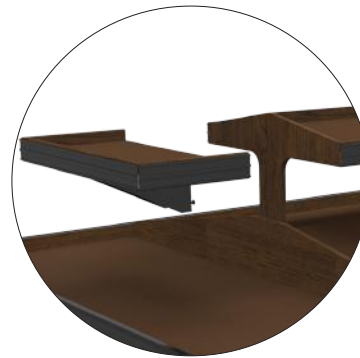

MULTI-TIER DOUBLE SIDED TABLE

ANGLED DECK

Clear finish shown



Oiled Cherry finish shown. Other finishes available - see chart.

MODEL	DESCRIPTION	LENGTH	DEPTH	HEIGHT
TBFD-023-01B	Multi-Tier Double Sided Angled Deck - 48"	47 1/2"	79"	52"
TBFD-023-01C	Double Sided Angled Deck - 48"	47 1/2"	79"	32"
SHCM-014-14.25-29.50	Mounted Shelf	29 1/2"	14 1/4"	3"

FEATURES:

- Birch/maple plywood, MDF and solid maple construction
- 3 Track sign holder
- Locking casters
- 1 1/2" ABS bumper

OPTIONS:

- Mounted side shelf
- Refer to Wood Stains Finishes

Note: Information and specifications may change due to engineering improvements.

Optional Mounted Shelf

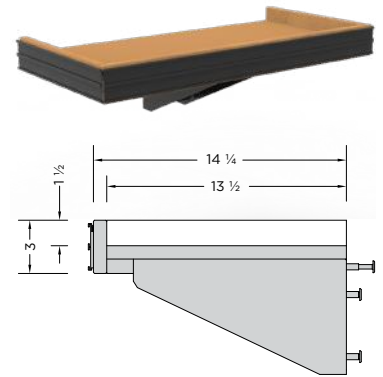
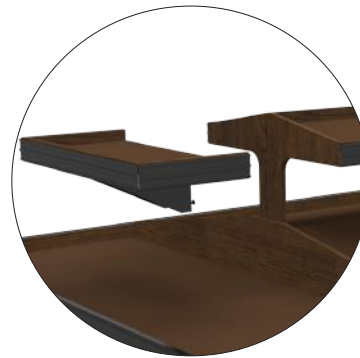

SHCM-014-14.25-29.50

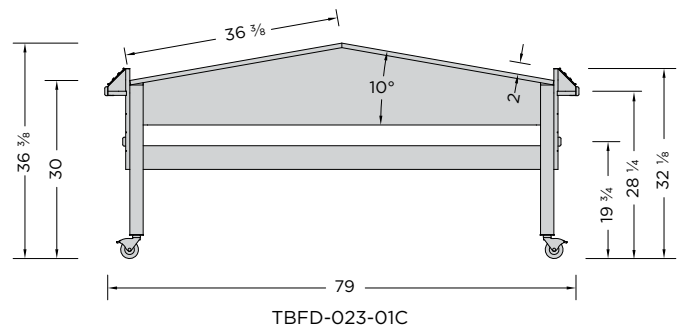
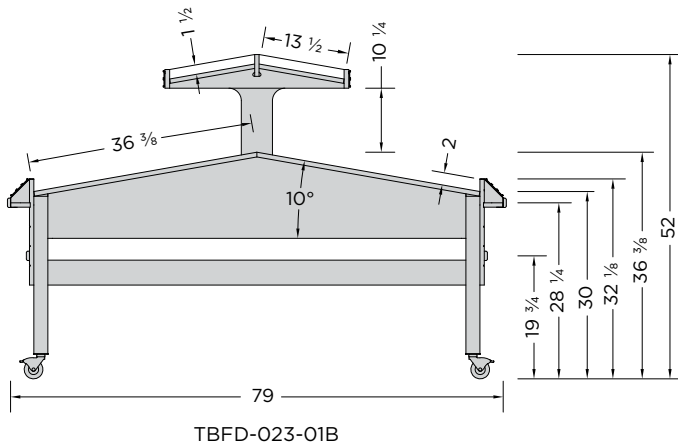

END CAP TABLE

SMALL DEPTH



Clear finish shown



Danish Walnut finish shown. Other finishes available - see chart.

MODEL	DESCRIPTION	LENGTH	DEPTH	HEIGHT
TBIE-053-01B	End Cap Table - Small	77 1/8"	33"	32 1/8"
TBIE-053-01C	End Cap Table w/ Rear Product Stop - Small	77 1/8"	33"	38 1/8"

FEATURES:

- Birch/maple plywood, MDF and solid maple construction
- Protective corner guards
- 3 Track sign holder
- Locking casters
- 1 1/2" ABS bumper

OPTIONS:

- Refer to Wood Stains Finishes

Note: Information and specifications may change due to engineering improvements.

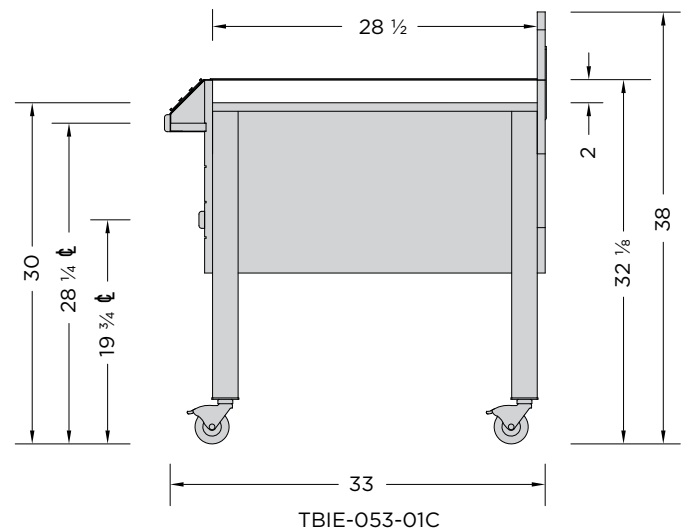
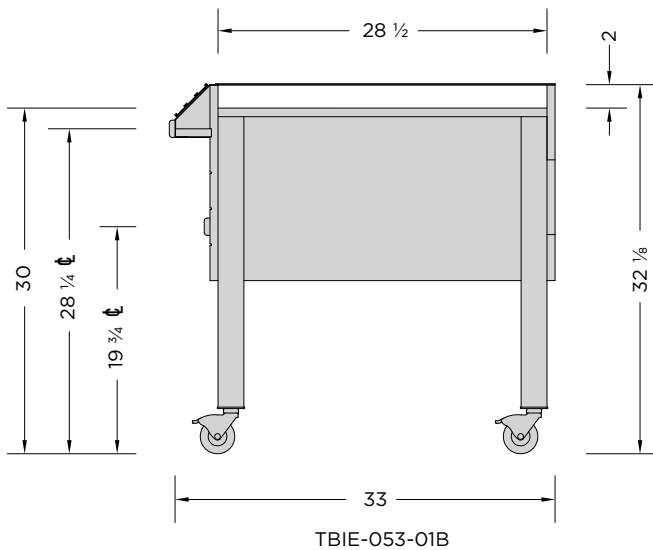

END CAP TABLE

LARGE DEPTH

Clear finish shown



Weathered Wood finish shown. Other finishes available - see chart.

MODEL	DESCRIPTION	LENGTH	DEPTH	HEIGHT
TBIE-070-01B	End Cap Table - Large	79"	39 1/2"	32 1/8"
TBIE-070-01C	End Cap Table w/ Rear Product Stop - Large	79"	39 1/2"	38 1/8"

FEATURES:

- Birch/maple plywood, MDF and solid maple construction
- Protective corner guards
- 3 Track sign holder
- Locking casters
- 1 1/2" ABS bumper

OPTIONS:

- Banana Riser
- Refer to Wood Stains Finishes

Note: Information and specifications may change due to engineering improvements.

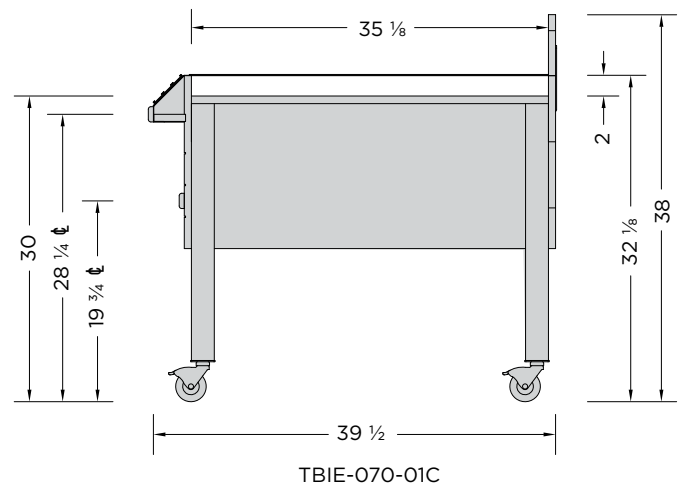
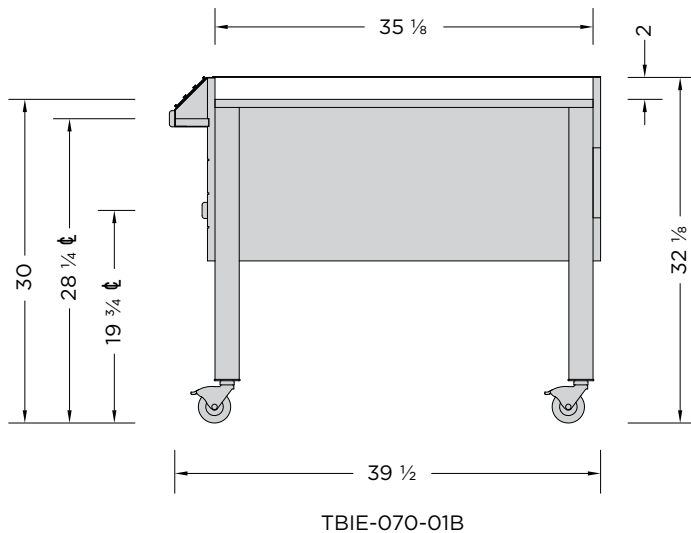

BANANA RISER



MODEL	DESCRIPTION	LENGTH	DEPTH	HEIGHT
ACRI-049-01A	Banana Riser	70"	34 1/4"	18 3/4"

FEATURES:

- Black ABS construction

Note: Information and specifications may change due to engineering improvements.

**** BANANA RISER ONLY WORKS WITH TABLES TBIE-070-01B OR TBIE-070-01C ****



TBIE-070-01B w/Banana Riser shown.

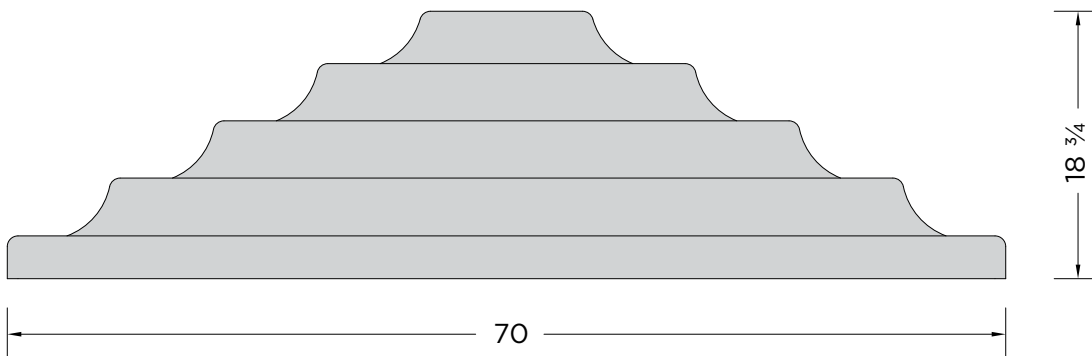

ACRI-049-01A

MULTI-TIER TABLE

Finish: Natural Maple

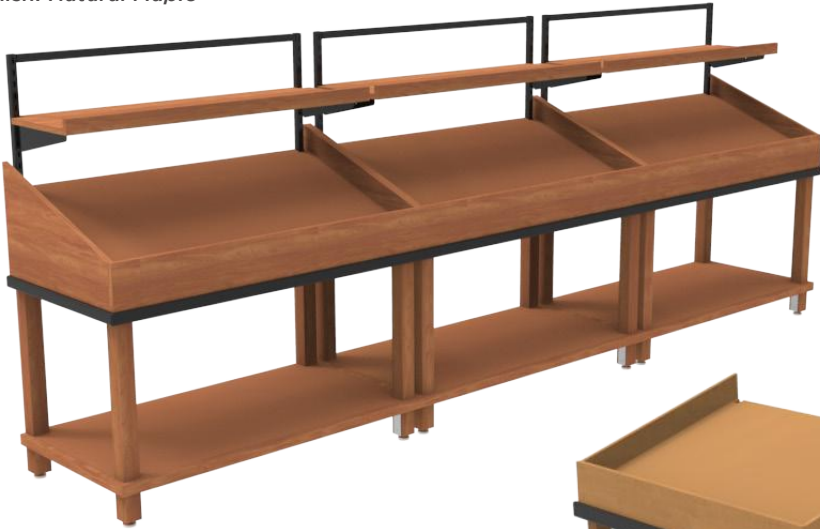

12'L Multi-Tier Single Sided Table shown
(refer to page 13)

Finish: Natural Maple

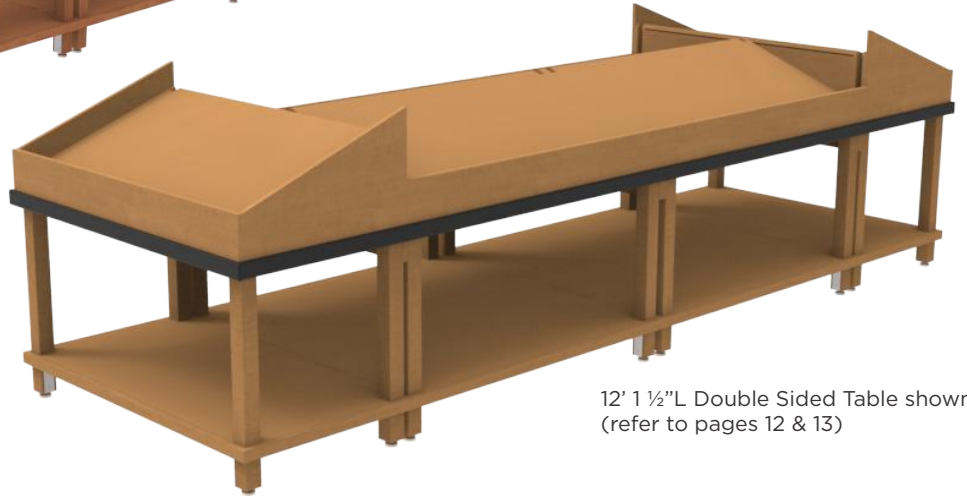

12' 1 1/2"L Double Sided Table shown
(refer to pages 12 & 13)



12' 1 1/2"L Multi-Tier Double Sided Table shown
(refer to pages 12 & 13)

Finish: Weathered Wood

Applications

- The multi-tier table is designed to be easily installed into an island or single sided set up, with optional adjustable upper shelf/metal frame and base merchandising
- Main table deck sits at a fixed 20° angle
- ABS bumper and levelers
- Protective corner guards and data strip available upon request

DOUBLE SIDED MULTI-TIER TABLE



MODEL	DESCRIPTION	LENGTH	DEPTH	HEIGHT
TBFD-001-01D	Double Sided Multi-Tier Table- 48"	48"	48"	38 1/4"
TBFD-001-01B	Double Sided Multi-Tier Table w/ Shelf- 48"	48"	48"	54 7/8"

FEATURES:

- Birch/maple plywood, MDF and solid maple construction
- Lower merchandising shelf
- Adjustable nylon levelers
- 1 1/2" ABS bumper

OPTIONS:

- Adjustable 14" deep plywood shelf on metal brackets w/ metal uprights (Angle: 0°, 15° or 30°)
- Bag holder, signage, data strips, product stops and product dividers also available
- Refer to Wood Stains Finishes

Note: Information and specifications may change due to engineering improvements.

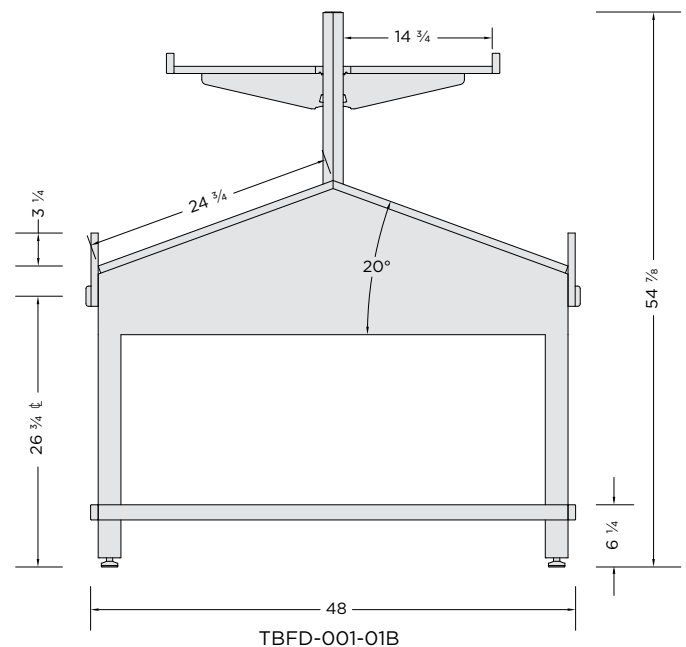
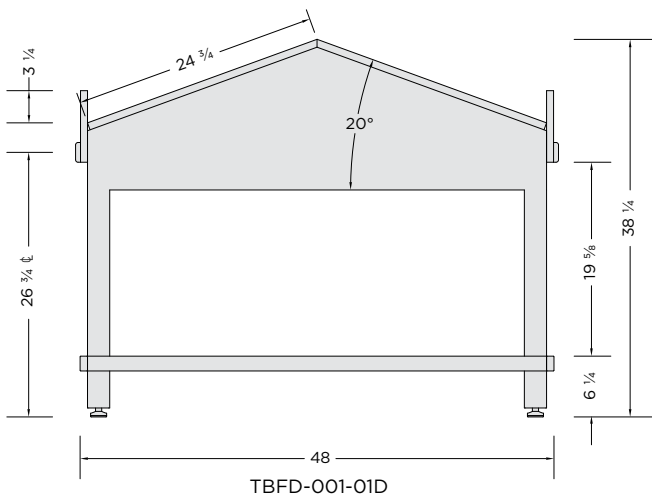

SINGLE SIDED MULTI-TIER TABLE



MODEL	DESCRIPTION	LENGTH	DEPTH	HEIGHT
TBIE-003-01L	Single Sided Multi-Tier Table	48"	24 3/4"	41 3/4"
TBIE-003-01E	Single Sided Multi-Tier Table w/ Shelf	48"	24 3/4"	54 7/8"

FEATURES:

- Birch/maple plywood, MDF and solid maple construction
- Lower merchandising shelf
- Adjustable nylon levelers
- 1 1/2" ABS bumper

OPTIONS:

- Adjustable 14" deep plywood shelf on metal brackets w/ metal uprights (Angle: 0°, 15° or 30°)
- Bag holder, signage, data strips, product stops and product dividers also available
- Bag holder and signage also available
- Refer to Wood Stains Finishes

Note: Information and specifications may change due to engineering improvements.

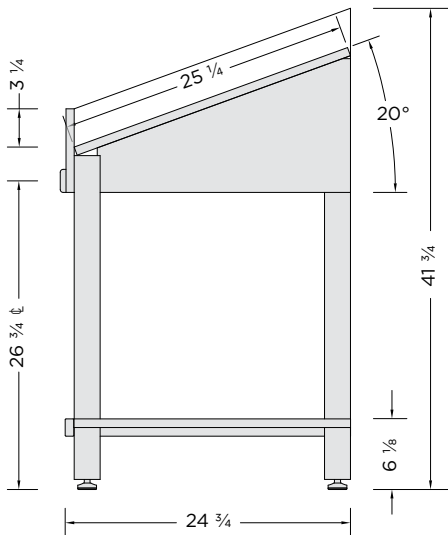

TBIE-003-01L

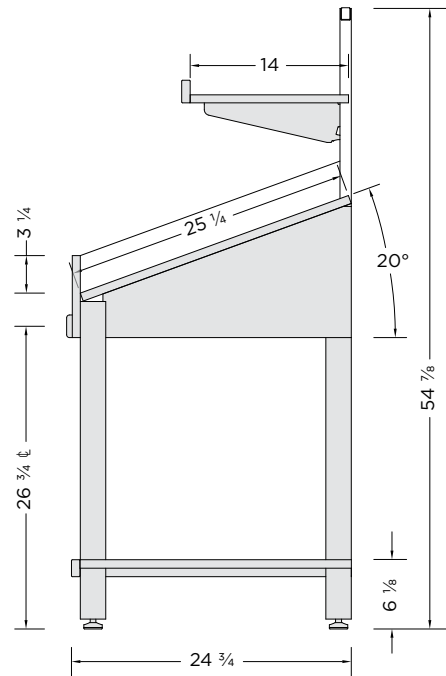

TBIE-003-01E

ISLAND PRODUCE TABLES

Finish: Natural Maple



17' 14 1/2" L Island Tables shown
(refer to pages 15 & 16)



11' 11 1/2" L Island Tables shown
(refer to pages 15 & 16)

Applications

- Island produce tables are designed to easily line up into run as well as provide a seamless look
- Units are easily connected with furniture supplied bolts. Center units come with the 16" pedestal attached to the unit while the 24" pedestal is shipped loose and requires fastening upon assemble of island (fasteners supplied)
- Center divider
- Data strip, ABS bumper and levelers

TABLE WITH OPEN BASE STORAGE

Clear finish shown



Danish Walnut finish shown. Other finishes available - see chart.

MODEL	DESCRIPTION	LENGTH	DEPTH	HEIGHT
TBFD-021-01B	Table w/ Open Base Storage	72"	35 1/2"	45 1/2"

FEATURES:

- Birch/maple plywood and solid maple construction
- Base merchandising with adjustable shelf on shelf pins
- Data strip and product stops
- Levelers
- 1 1/2" ABS bumper
- Designed to work with TBIE-069-01B

OPTIONS:

- Refer to Wood Stains Finishes

Note: Information and specifications may change due to engineering improvements.

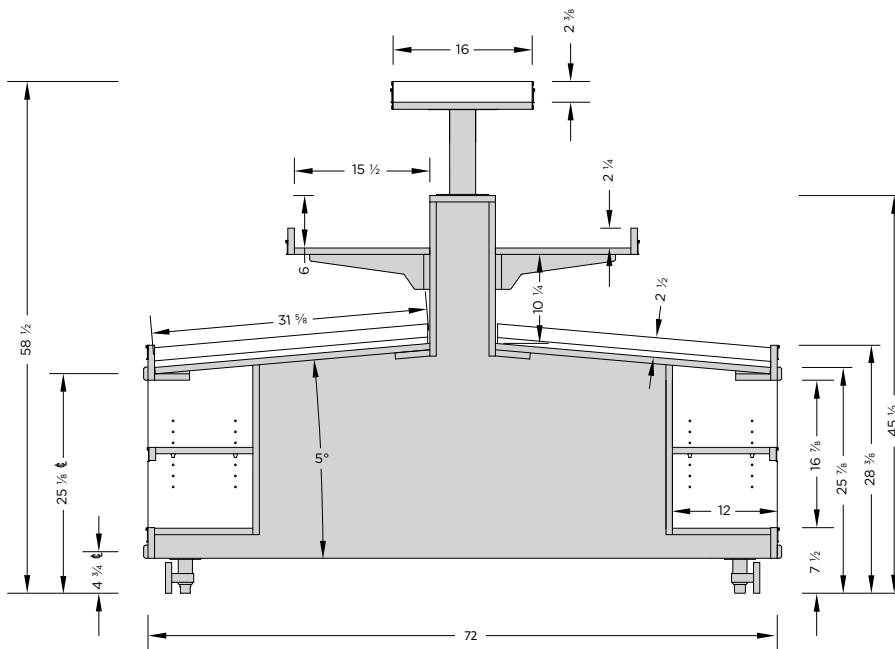

TBFD-021-02B

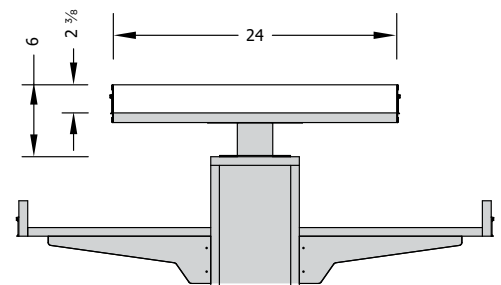

ACRI-061-01A

24" Pedestal (shipped loose)
With locator holes, Allen key, and furniture bolts, assembly is simple. No other equipment is needed.)

END CAP TABLE WITH OPEN BASE STORAGE



Removable Product Dividers

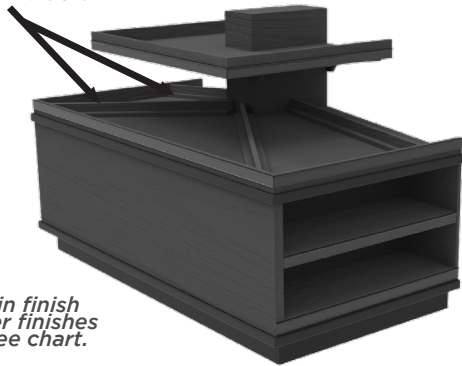

Iron Mountain finish shown. Other finishes available - see chart.

MODEL	DESCRIPTION	LENGTH	DEPTH	HEIGHT
TBIE-069-01B	End Cap Table w/ Open Base Storage	72"	36 1/4"	45 1/2"

FEATURES:

- Birch/maple plywood and solid maple construction
- Base merchandising with adjustable shelf on shelf pins
- Data strip and product stops
- Levelers
- 1 1/2" ABS bumper
- Designed to work with Tbfd-021-02B

OPTIONS:

- Refer to Wood Stains Finishes

Note: Information and specifications may change due to engineering improvements.

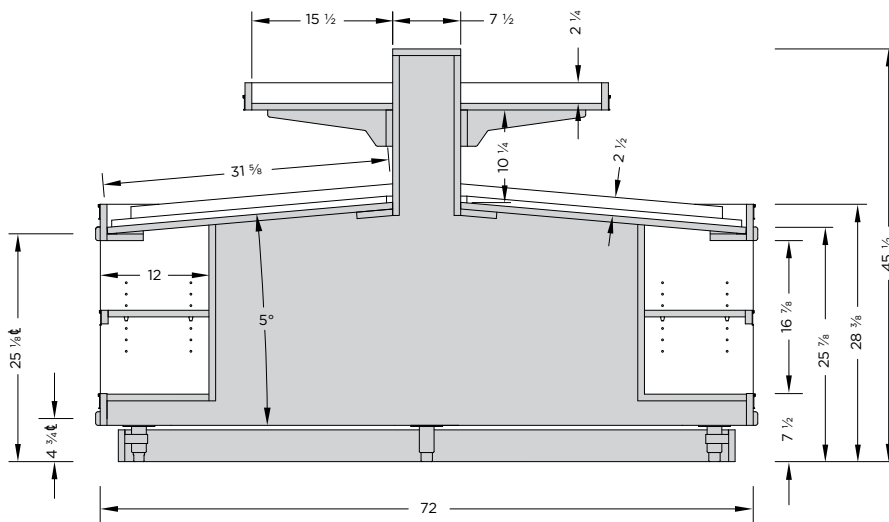

TBIE-069-01B

MARKET BIN

8' 11 ¼"L Market Bin w/ Base Merchandising shown
(refer to pages 21 & 22)



Finish: Weathered Wood



5' 11 ½"L Market Bin shown
(refer to pages 18 & 22)

Finish: Natural Maple

Finish: Select Cherry



8' 11 ¼"L Market Bin shown
(refer to pages 19, 22 & 23)

Applications

- The market bin collection can be stand-alone, line-up or island configurations

MARKET BIN

Clear finish shown



Oiled Cherry finish w/optional ABS Tray shown.



Weathered Wood finish w/optional Wire Cage & ABS Liner shown. Other finishes available - see chart.

MODEL	DESCRIPTION	LENGTH	DEPTH	HEIGHT
TBOR-060-01B	Market Bin	35 3/4"	35 3/4"	31 1/4"
TBOR-061-01B	Market Bin - Tall	35 3/4"	35 3/4"	35 1/4"

FEATURES:

- Birch/maple plywood and MDF construction
- Nylon tack glides
- Corner guards

OPTIONS:

- ABS haircell liner
- ABS tray (no drain)
- Wire cage
- Heavy duty casters (2 locking)
- 1 1/2" ABS bumper
- Refer to Wood Stains Finishes

Note: Information and specifications may change due to engineering improvements.

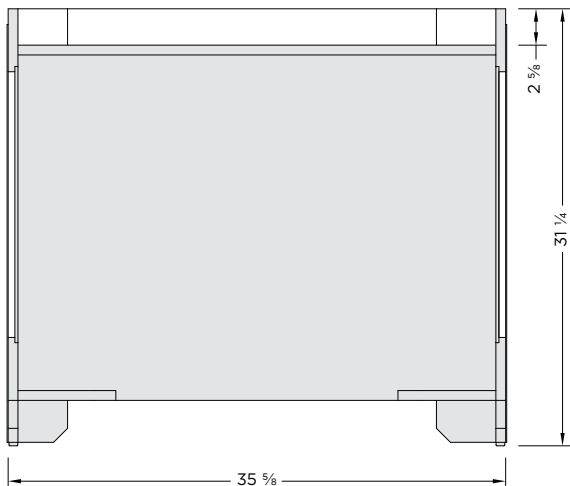

TBOR-060-01B

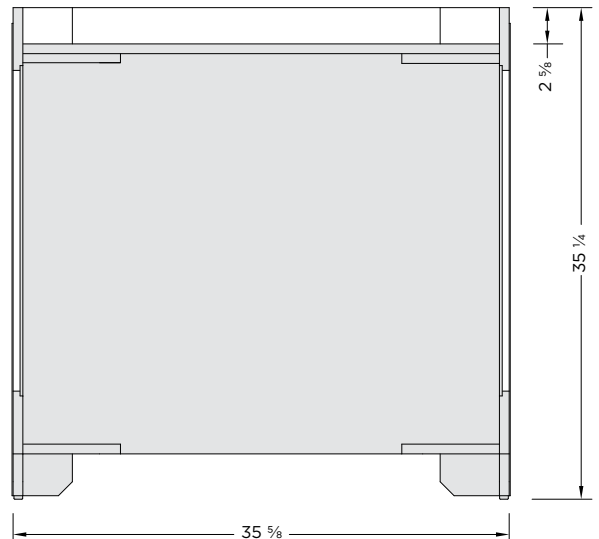

TBOR-061-01B

MARKET BIN WITH BASE MERCHANDISING



MODEL	DESCRIPTION	LENGTH	DEPTH	HEIGHT
TBOR-062-01B	Market Bin	35 3/4"	35 3/4"	31 1/4"
TBOR-063-01B	Market Bin - Tall	35 3/4"	35 3/4"	35 1/4"

FEATURES:

- Birch/maple plywood, solid maple, melamine and MDF construction
- Nylon tack glides
- Corner guards

OPTIONS:

- ABS haircell liner
- ABS tray (no drain)
- Wire cage
- Heavy duty casters (2 locking)
- 1 1/2" ABS bumper
- Refer to Wood Stains Finishes

Note: Information and specifications may change due to engineering improvements.

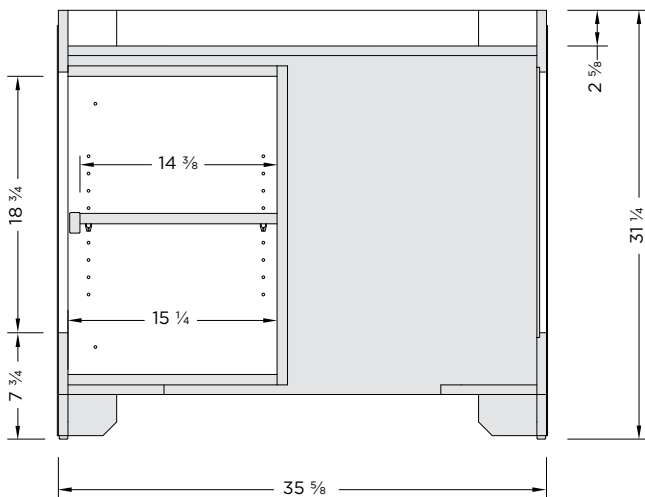

TBOR-062-01B

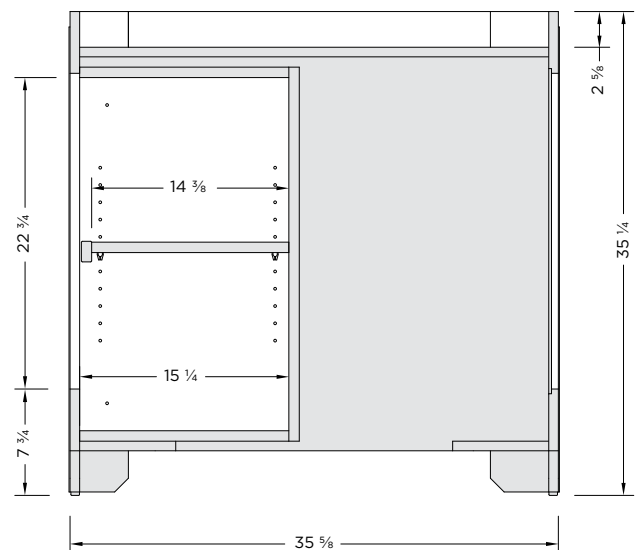

TBOR-063-01B

MARKET ICE BIN

Clear finish shown



Iron Mountain finish shown. Other finishes available - see chart.



MODEL	DESCRIPTION	LENGTH	DEPTH	HEIGHT
TBOR-064-01B	Market Ice Bin with ABS Tray	35 3/4"	35 3/4"	31 3/8"
TBOR-065-01B	Market Ice Bin with ABS Tray - Tall	35 3/4"	35 3/4"	35 3/8"

FEATURES:

- Birch/maple plywood and MDF construction
- Nylon tack glides
- Corner guards
- ABS tray with insulation, drain, valve, hose, 5 gallon bucket & access door

OPTIONS:

- 1 1/2" ABS bumper
- Heavy duty casters (2 locking)
- Refer to Wood Stains Finishes

Note: Information and specifications may change due to engineering improvements.

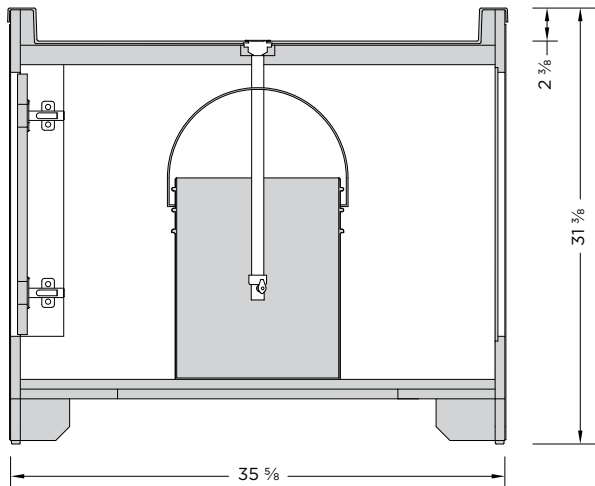

TBOR-064-01B

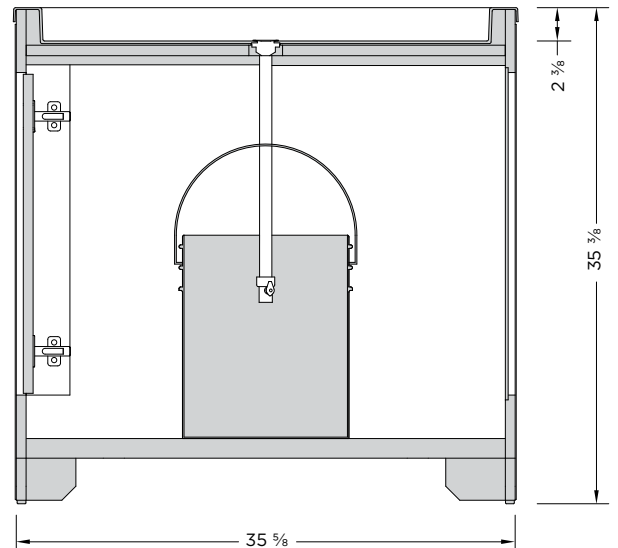

TBOR-065-01B

MARKET ICE BIN WITH BASE MERCHANDISING

Clear finish shown



Choco Cherry finish shown. Other finishes available - see chart.

MODEL	DESCRIPTION	LENGTH	DEPTH	HEIGHT
TBOR-066-01B	Market Ice Bin with ABS Tray	35 3/4"	35 3/4"	31 3/8"
TBOR-067-01B	Market Ice Bin with ABS Tray - Tall	35 3/4"	35 3/4"	35 3/8"

FEATURES:

- Birch/maple plywood, solid maple, melamine and MDF construction
- Nylon tack glides
- Corner guards
- ABS tray with insulation, drain, valve, hose, 5 gallon bucket & access door

OPTIONS:

- 1 1/2" ABS bumper
- Heavy duty casters (2 locking)
- Refer to Wood Stains Finishes

Note: Information and specifications may change due to engineering improvements.

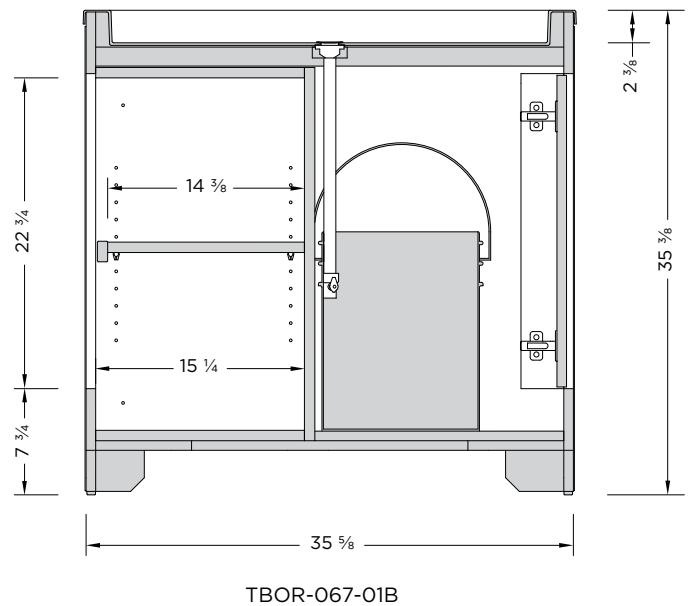
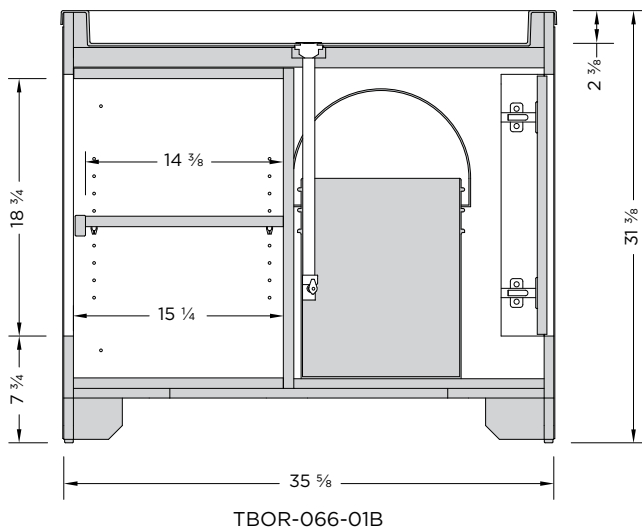

WING TABLES - 3 OPEN SIDES



Clear finish shown



Weathered Wood finish w/optional ABS Tray shown. Other finishes available - see chart.

MODEL	DESCRIPTION	LENGTH	DEPTH	HEIGHT
TBOR-078-01B	Wing Table - 3 Open Sides	34 7/8"	17 7/8"	31 1/4"
TBOR-078-01C	Wing Table - 3 Open Sides w/ ABS Tray	35 3/8"	18 3/8"	31 3/8"

FEATURES:

- Birch/maple plywood and solid maple construction
- Adjustable shelf on shelf pins
- Nylon tack glides
- Protective corner guards
- TBOR-078-01C
 - ABS tray without drain

OPTIONS:

- ABS haircell liner
- 1/2" Foam insert
- 1 1/2" ABS bumper
- Refer to Wood Stains Finishes

Note: Information and specifications may change due to engineering improvements.

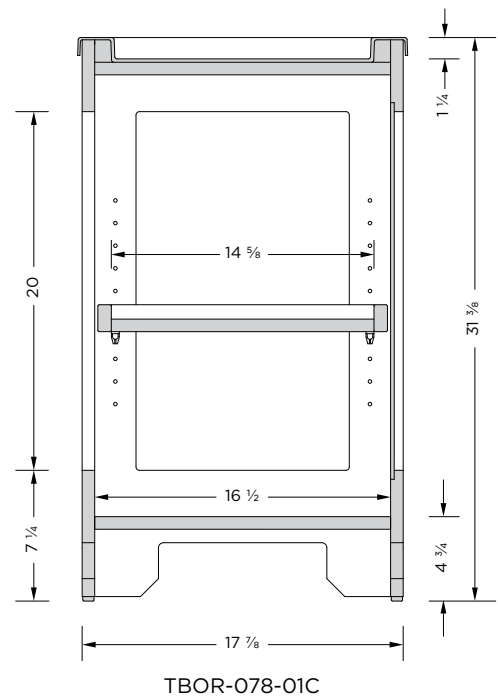
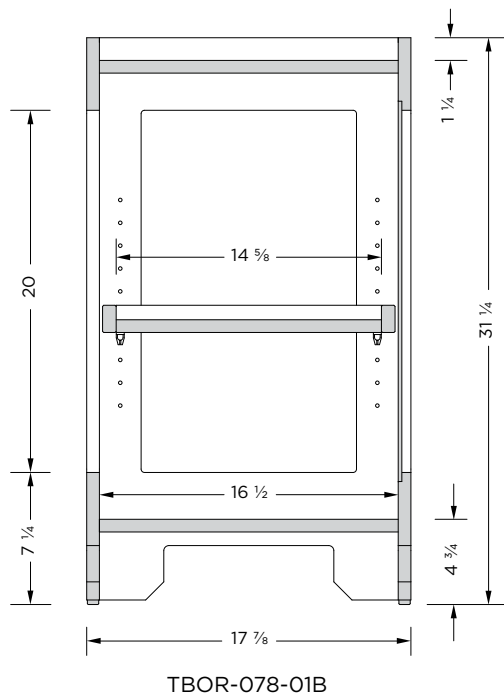

CLOSED WING TABLES

Clear finish shown



Concerto finish w/
optional ABS Tray
shown. Other finishes
available - see chart.

MODEL	DESCRIPTION	LENGTH	DEPTH	HEIGHT
TBOR-079-01B	Closed Wing Table	34 7/8"	17 7/8"	31 1/4"
TBOR-079-01C	Closed Wing Table w/ ABS Tray	35 3/8"	18 3/8"	31 3/8"

FEATURES:

- Birch/maple plywood and solid maple construction
- Adjustable shelf on shelf pins
- Nylon tack glides
- Protective corner guards
- TBOR-079-01C
 - ABS tray without drain

OPTIONS:

- ABS haircell liner
- 1/2" Foam insert
- 1 1/2" ABS bumper
- Refer to Wood Stains Finishes

Note: Information and specifications may change due to engineering improvements.

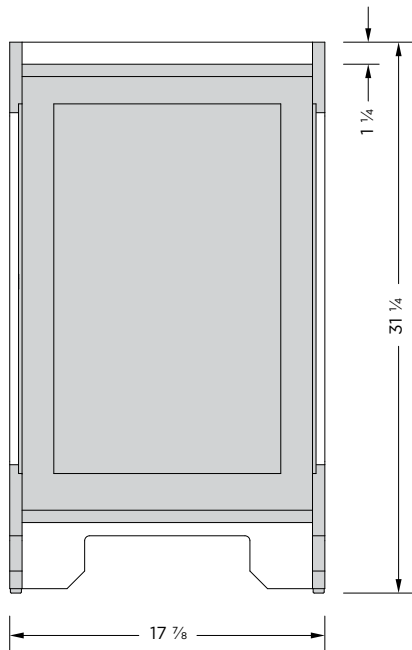

TBOR-079-01B

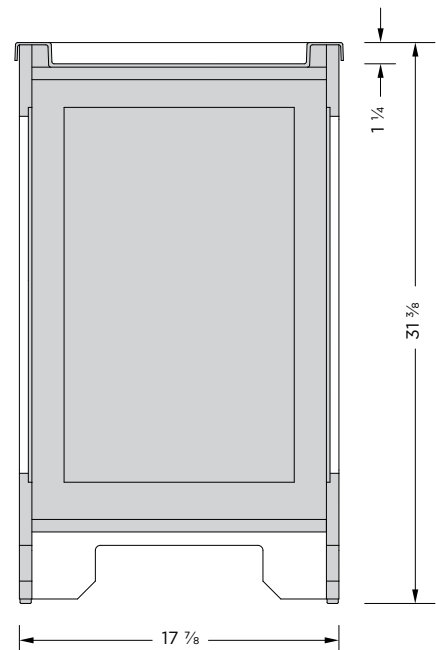

TBOR-079-01C

NARROW MULTI-SHELF TABLE



Weathered Wood finish shown. Other finishes available - see chart.

MODEL	DESCRIPTION	LENGTH	DEPTH	HEIGHT
TBFS-002-01B	Multi-Shelf Table - 48"	47 ½"	29"	55"
TBFS-002-02B	Multi-Shelf Table - 36"	35 ½"	29"	55"

FEATURES:

- Birch/maple plywood construction and solid maple trims
- 1-13" & 1-18" adjustable wood shelves with 3" front product stop (shelves can be canted) Heavy duty casters (2 locking)
- Open base merchandising area
- Adjustable bottom shelf
- 1 ½" ABS bumper

OPTIONS:

- Refer to Wood Stains Finishes

Note: Information and specifications may change due to engineering improvements.

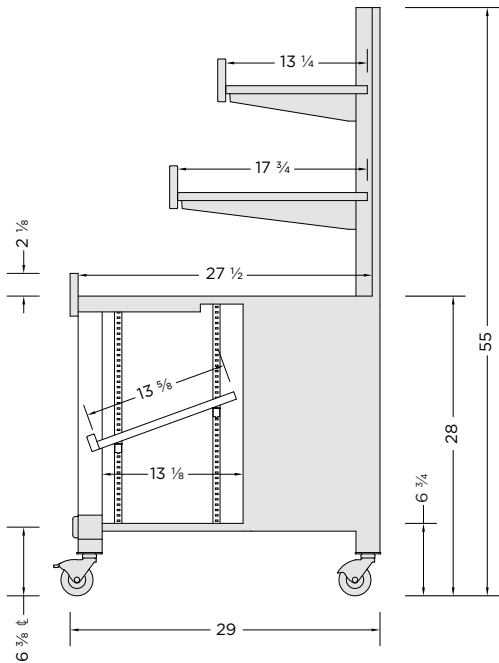

TBFS-002-01B (47 ½"L) & TBFS-002-02B (35 ½"L)

ACCESSORIES

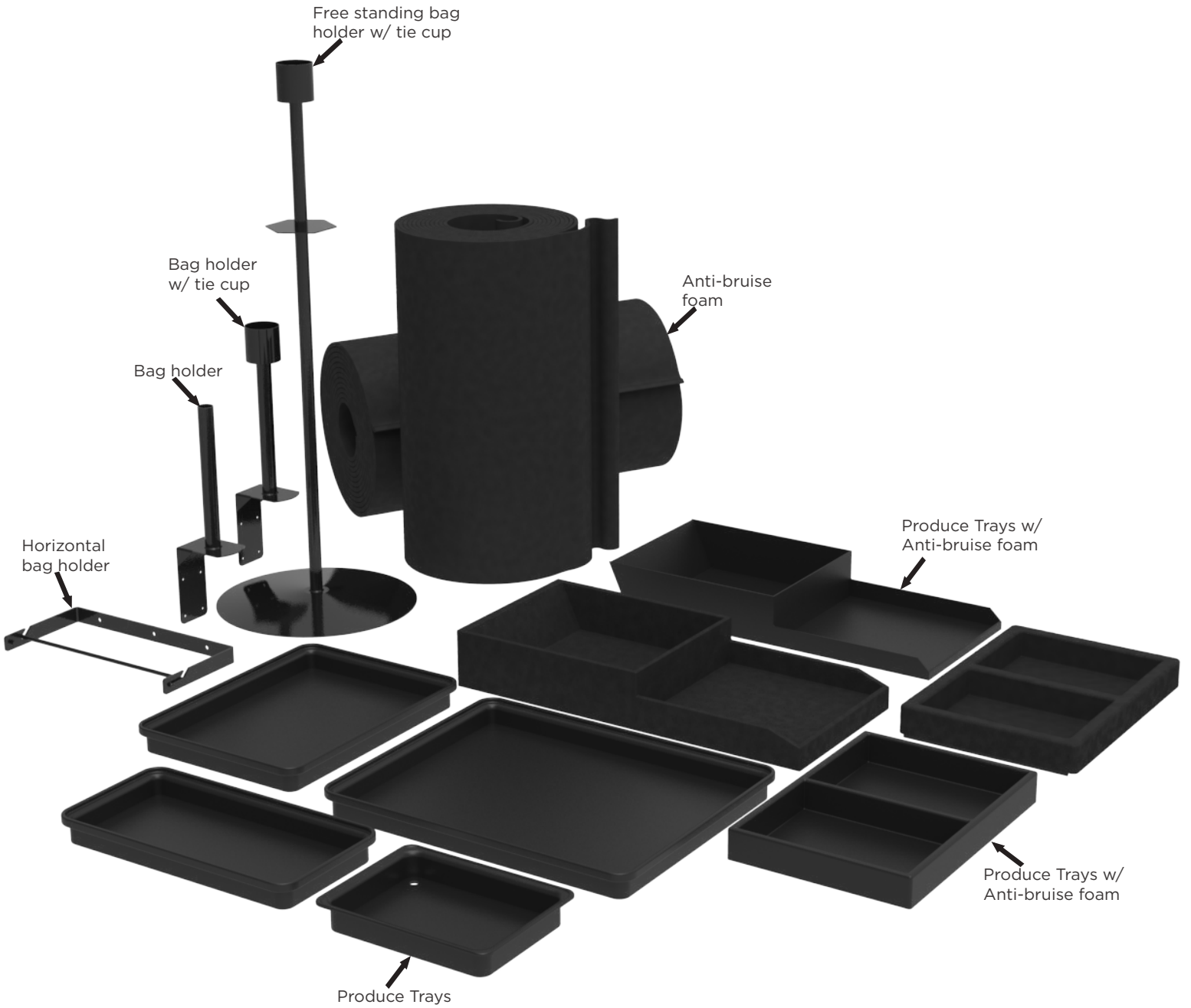

BAG HOLDER

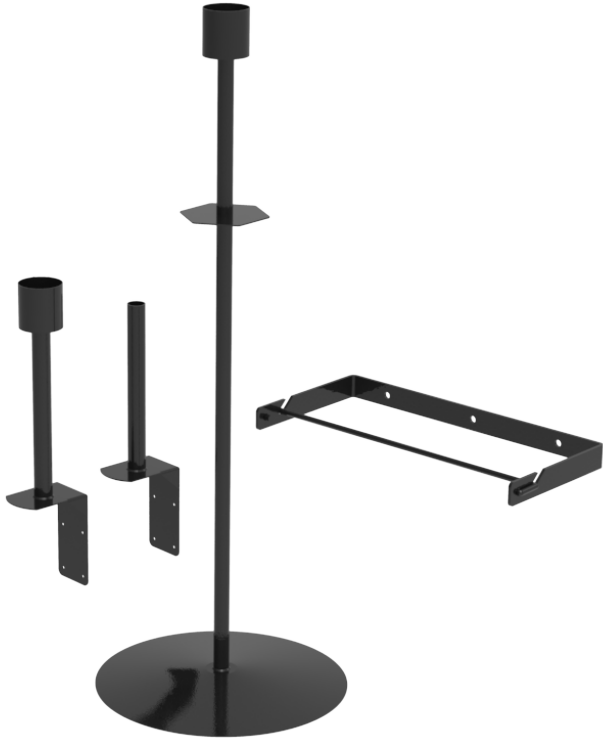

MODEL	DESCRIPTION	LENGTH	DEPTH	HEIGHT
182PBAGHOLDER	Horizontal Bag Holder	13 ¼"	6 ¼"	-
ACBH-003-01B	Free Standing Bag Holder w/ Tie Cup	20"Ø	-	50 ¼"
ACBH-004-01A	Screw On Bag Holder	4"	6"	22"
ACBH-004-01B	Screw On Bag Holder w/ Tie Cup	4"	6"	25 ½"

FEATURES:

- Metal construction powder coated black

Note: Information and specifications may change due to engineering improvements.

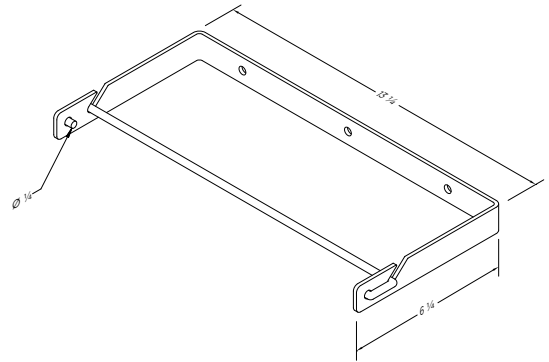

182PBAGHOLDER

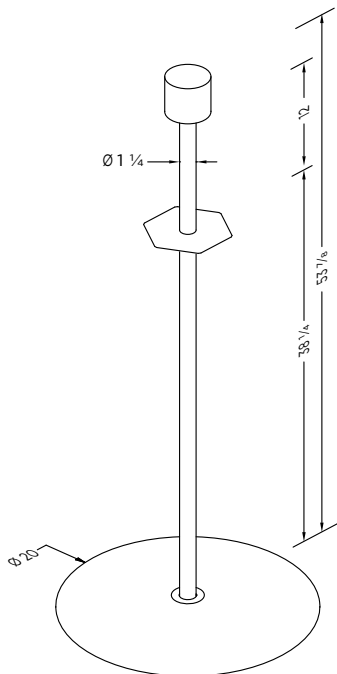

ACBH-003-01B

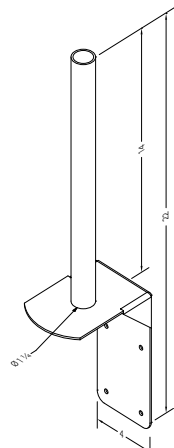

ACBH-004-01A

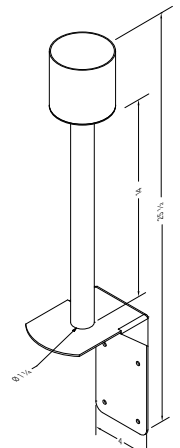

ACBH-004-01B

PRODUCE TRAY

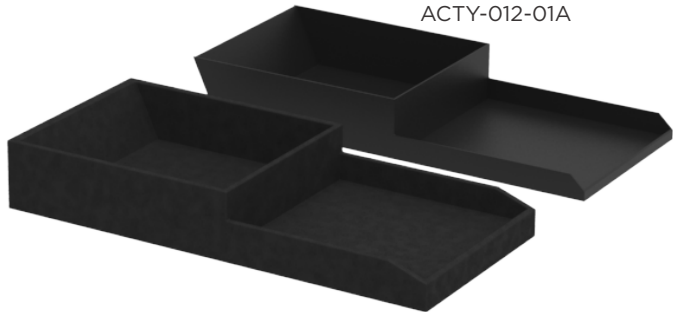

ACTY-012-01A



ACTY-010-01A

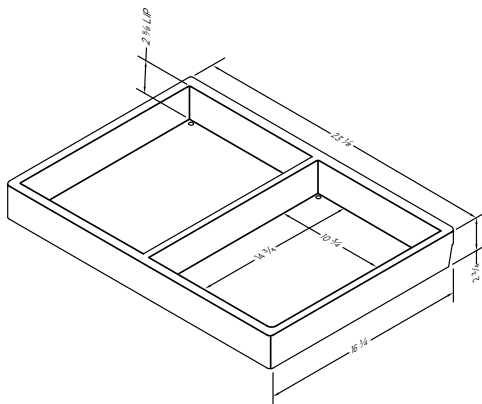

ACTY-010-01A

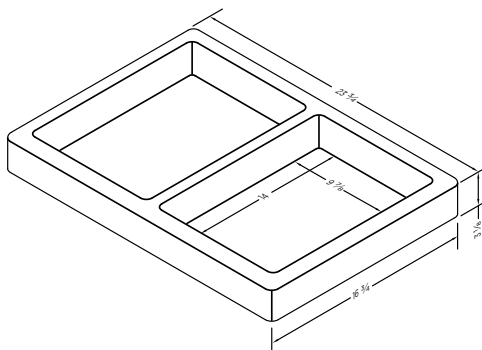

ACTY-011-01A

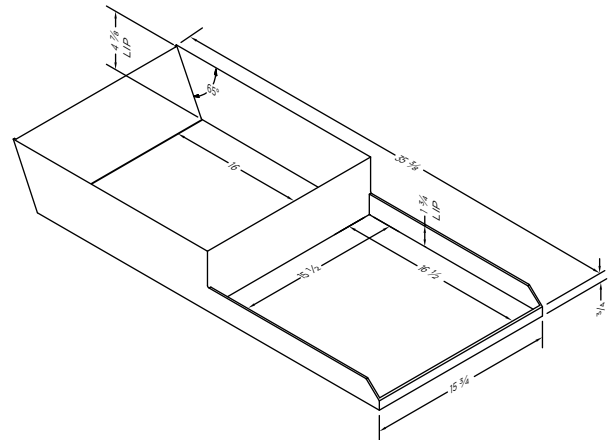

ACTY-012-01A

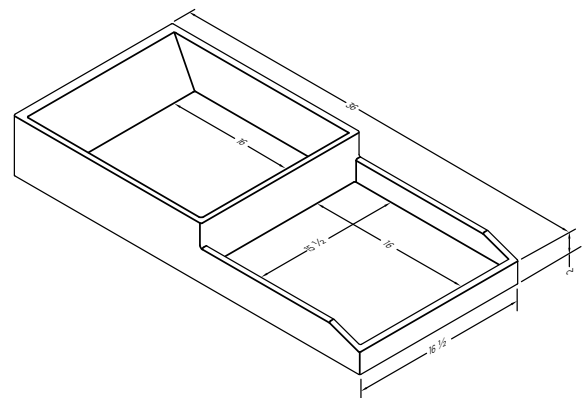

ACTY-013-01A

MODEL	DESCRIPTION	LENGTH	DEPTH	HEIGHT
ACTY-012-01A	Produce Tray - Two Tie	35 3/8"	15 3/4"	5 1/2"
ACTY-013-01A	Anti-bruise foam for ACTY-012-01A			
ACTY-010-01A	Produce Tray - Two Compartment	23 1/8"	16 1/4"	2 3/4"
ACTY-011-01A	Anti-bruise foam for ACTY-010-01A			

FEATURES:

- Black ABS construction
- Black anti-bruise closed cell foam
- Trays designed to work with TBTS-005 tables

Note: Information and specifications may change due to engineering improvements.

PRODUCE TRAY WITH LIP



MODEL	DESCRIPTION	LENGTH	DEPTH	HEIGHT
ACTY-007-01A	Produce Tray -Lip	24"	30"	2 ½"
ACTY-008-01A	Produce Tray -Lip	24"	18"	2 ½"
ACTY-009-01A	Produce Tray -Lip	24"	12"	2 ½"
ACTY-014-01A	Produce Tray -Lip	16"	12"	2 ½"

FEATURES:

- Black ABS construction
- Drainage holes
- Min qty = 20

Note: Information and specifications may change due to engineering improvements.

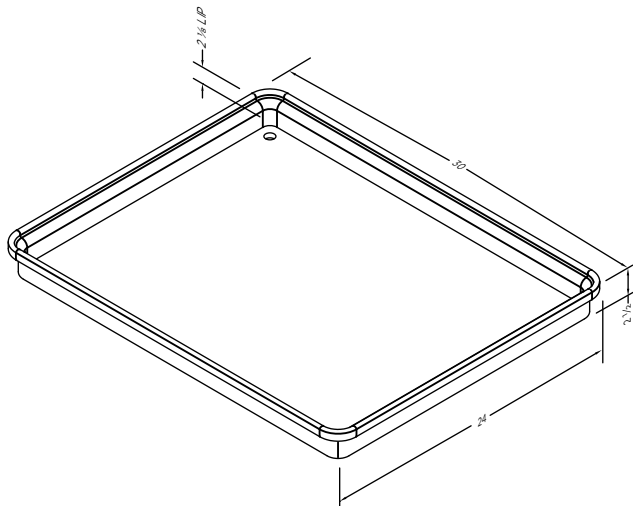

ACTY-007-01A

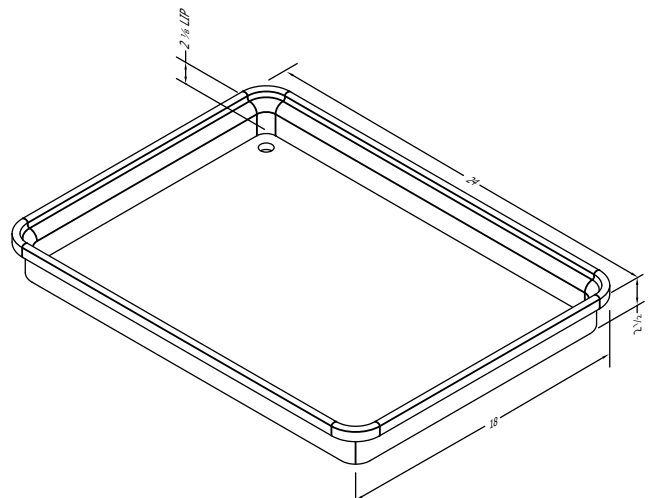

ACTY-008-01A

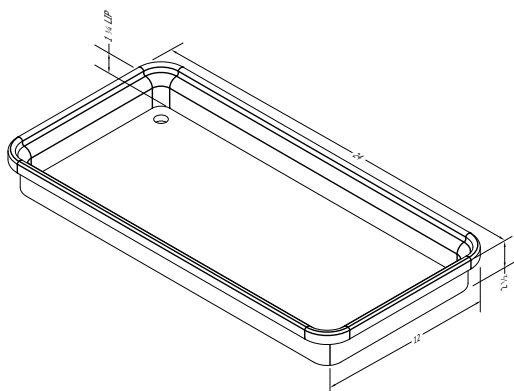

ACTY-009-01A

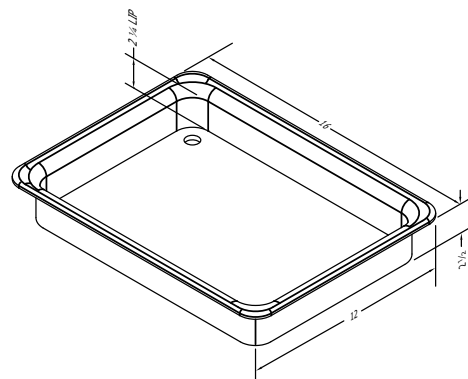

ACTY-014-01A

ANTI-BRUISE FOAM MATTING - ROLL



MODEL	DESCRIPTION	LENGTH	DEPTH	HEIGHT
CCA-100	Anti-Bruise Foam Matting - Roll	200'	60"	3/8"

FEATURES:

- 3/8" thick foam matting
- 200' roll

Note: Information and specifications may change due to engineering improvements.

CLAMP ON SIGN FRAME

Clear finish shown



MODEL	DESCRIPTION	LENGTH	DEPTH	HEIGHT
ACSN-002-01B	Clamp On Sign Frame	36"	1 ½"	15 ¼"

FEATURES:

- Solid maple construction
- Clamping mechanism to attach sign to rear tilting deck of table
- Sign frame is able to tilt allowing frame to sit vertical with floor
- 3 track Washington Poster
- Works with both 3' & 4' tilt-top table

OPTIONS:

- Refer to Wood Stains Finishes

Note: Information and specifications may change due to engineering improvements.

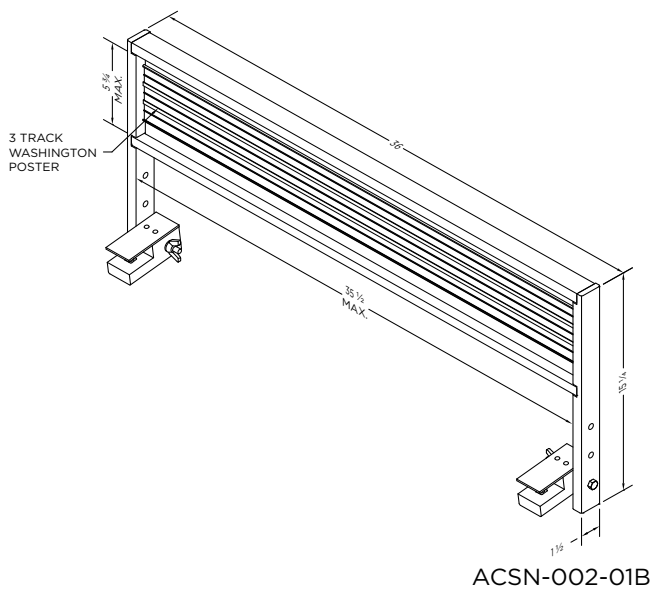



Formica® Laminate

Formica Group provides surfaces that fuse beautiful design with purposeful functionality. Formica® Products provide versatile surfacing solutions that are inspired by and adapt to the way people live, work and play.

Formica® Brand Laminate offers a broader range of looks than ever before. Transform spaces with our modern laminates that are as beautiful as they are durable. Mix and match solids, patterns and finishes.

Product Features:

- Postforming
- Durable and Wear-resistant
- Horizontal and Vertical
- Impact Resistant

Formica® EliteForm

Our innovative Formica® EliteForm surfacing technology redefines the performance attributes of high pressure laminate to deliver a more durable laminate for today’s market. Formica® Laminate with EliteForm features superior scratch resistance over other laminate brands, the ability to postform to a smaller radius with better blister resistance, and more durable, long-lasting surfaces, including the Gloss texture in horizontal applications. EliteForm comes standard on all Formica® Laminates, at no additional cost.

Price Group One: All Colours are matte (-58) finish

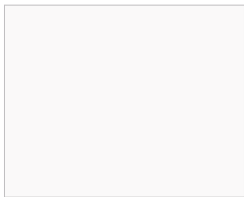

949
White

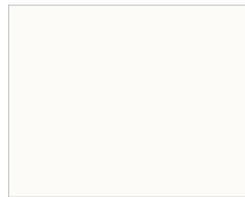

7197
Dover White

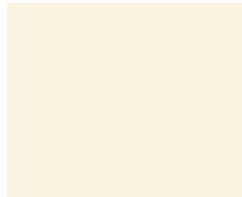

920
Almond

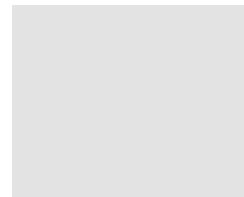

927
Folkstone



961
Fog



845
Spectrum Red



7897
Spectrum Green



914
Marine Blue



2297
Terril

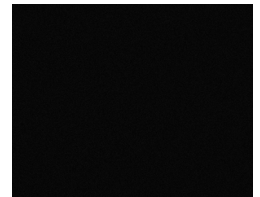

909
Black



6696
Carrara Bianco

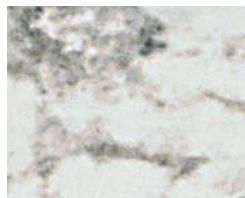

9476
White Ice Granite



9497
Silver Quartzite



7732
Butterum Granite

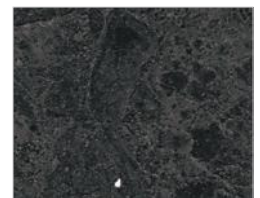

9527
Black Shalestone



8844
Aged Ash

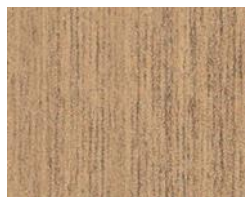

5883
Pecan Woodline

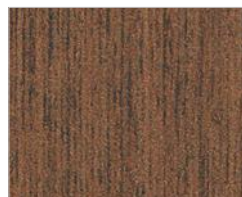

5884
Chestnut Woodline



9283
Walnut Riftwood



6414
Black Riftwood

Price Group Two: All Colours are matte finish



6997
Pale Brushstroke



6998
Wood Brushstroke



7813
Cardboard Solidz



9319
Stainless



8918
Blackened Steel



9310
White Marble Herringbone



9285
White Twill

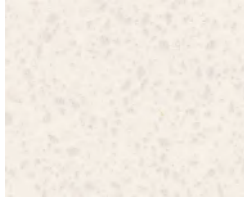

6698
Paloma Pear



503
Stone Grafix



8830
Elemental Concrete



8841
White Ash



5785
Ashwood Beige



5795
Camel Elm



8845
Bleached Legno



8916
Blackened Fiberwood



86992
Hardrock Maple



7012
Amber Maple



8677
Scandi Rift Oak



6995
Cherry Walnut



7759
Select Cherry



Formica Canada Inc. is located in St-jean-sur-Richelieu, Quebec, and employs more than 250 people.

Formica Canada is proud to be part of the Well Made Here local purchasing program.

As the inventor of high pressure laminate, Formica Corporation has always worked to provide innovative, high quality products. Efficient use of resources is at our core, and we have taken many steps to improve our environmental footprint - from reusing the water in our presses to incorporating recycled materials into our surfacing products. We are committed to a long-term planning horizon that includes becoming an industry-leading environmental steward.



For larger laminate sample, please visit:
cayugadisplays.com 1-800-839-5536
formica.com 1-800-FORMICA™

PAINTED METAL

- **Standard products in stock**
- **RAL Program** colours not listed are also available upon request
- **Non-RAL Program** colours have long lead times and could affect deliver date

CAYUGA STOCK COLOURS



Cayuga Black



Cayuga White

Cayuga black and white colours come in a textured finish.

Matte finish is available upon request.

RAL STOCK COLOURS



Traffic Blue
Ral 5017

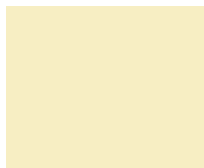

Cream
Ral 9001

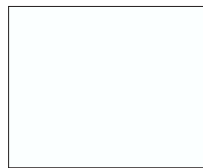

Pure White
Ral 9010



Traffic Orange
Ral 2009



Pebble Grey
Ral 7032



Basalt Grey
Ral 7012



Traffic Grey
Ral 7042



Quartz Grey
Ral 7039



Traffic Red
Ral 3020

WOOD STAINS

CAYUGA STANDARD WOOD GRAINS



Oiled Cherry
Match to Pionite/Panolam
WC421 (Oiled Cherry)



Wild Cherry
Match to Formica 5904-43
(Wild Cherry)



Select Cherry
Match to Formica 7759
(Select Cherry)



Choco Cherry
Match to Panval/Uniboard
207 (Choco Cherry)



Natural Maple
Match to Formica 86992-58
(Hardrock Maple)



Pearwood
Match to Pionite/Panolam
WX031 (Pearwood)

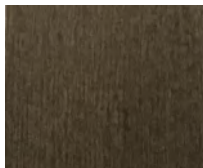

Weathered Wood
Match to Formica 8909-NF
(Cascara Teakwood)



Concerto
Match to Arborite T485/
Tafisa L485 (Concerto)

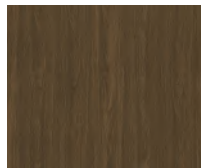

Danish Walnut
Match to Arborite W305
(Parliament Walnut)



Witchcraft
Match to Pionite/Panolam
WX421 (Witchcraft)



Iron Mountain
Match to Formica 912-58
(Storm)

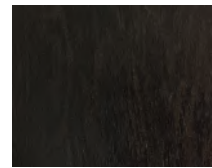

Baloil
Match to Formica 6414 NG
(Black Riftwood)

Refer to physical swatches for a true representation of colors, above images may appear slightly different than actual samples.

HOW TO ORDER

We'll help you select the right case for your requirements. The steps below will help us to serve you best.

- 1 Choose the showcase that meets your display requirements from the product specification sheets.
- 2 Review the options table found on the specification sheet and make your selections of the options provided.
- 3 Select from the large pallet of colours found on the last five pages of the brochure, or choose a stainless steel, standard black or white for the exterior finish of your showcase.
- 4 E-mail your request for a quote to your Cayuga sales representative or sales@cayugadisplays.com and we will quickly respond to your request. Please include your full contact information in case we have any questions.

Contact the inside sales team

Cayuga Displays

E: sales@cayugadisplays.com

T: 1-800-839-5536

F: 1-905-772-3179



T: 800.839.5536 F: 905.772.3179

E: sales@cayugadisplays.com

A: 88 Talbot St E, PO Box 130
Cayuga, ON N0A 1E0

