

2020

Product Catalog

lancerworldwide.com

LANCER[®]
W O R L D W I D E

Dedication in Action™

Lancer Worldwide

Lancer was founded more than fifty years ago with a promise never to compromise on quality. Based in San Antonio, Texas, Lancer manufactured parts for beverage dispensing machines. Lancer began creating original products, including the very first mechanically cooled beverage dispensers in 1971, and we've been leading innovators in the industry ever since.

Our commitment to creating new and improved beverage dispensing equipment is what sets us apart from the rest. We know that the technology in this industry changes quickly, so we put research and development at the core of our business from the very beginning. In the last five decades, we've taken dozens of original, patented products from concept to full production, including beverage and ice dispensers, valves, carbonators, syrup pumps, draft systems and more. In addition to developing new designs, we also work tirelessly to improve the quality and manufacturing efficiency of our existing products. Year after year, we invest millions of dollars into this work because we know it makes a difference for our customers.

We also pride ourselves on valuable partnerships with other leading companies in the food and beverage industry which allow us to provide the perfect machines and parts to deliver for their customers. These relationships have given us a global reach, which we augmented in the 1990s through the acquisition of beverage dispensing companies in Australia, New Zealand, Mexico, Russia, and Brazil. Our international presence and reputation for unmatched quality led to our acquisition in 2006 by Hoshizaki Corporation, the world's second-largest manufacturer of commercial kitchen equipment. With sales of over \$2 billion and a service network in over 60 countries, Hoshizaki has fueled Lancer Worldwide's growth and expanded our role as a global leader in beverage dispensing.

Table of Contents

Cold Carbonated Dispensers (CCD)

CCD Series - CED 8000 & CED 9000.....	2-3
Delta 600	4-5

Counter Electric Dispensers (CED)

CED - External Carbonation.....	6-7
CED - Ambient Non-Carbonated	8-9
CED - Pre-chillers 500-2500	10-11

Ice Beverage Dispensers (IBD)

4500 Series.....	12-13
Flavor Select	14-15
Sensation.....	16-17
TwinPour 44.....	18-19

Ice Cooled Drop In Dispensers (ICDI)

2200 & 2300 Standard Performance	20-21
2323 High Performance.....	22-23
23300 High Performance.....	24-25

Ice Chests & Ice Dispensers

IC400.....	26-27
ID4400	28-29

Marine.....

Refrigerated Beverage Dispensers (RBD)

Soochee	32-33
---------------	-------

Towers

Tower 300	34-35
TST	36-37
Unicorn	38-39

Valves

LEV®	40-41
VersaPour	42-43
Volumetric	44-45

Accessories

BIB Racks.....	46-47
Conversion Stands	48-49
Remote Chillers - Delta 9100 & 2500 Remote...50-51	
Turbo Carbonator.....	52-53

Kold Draft Systems

Towers & Drip Trays	54-55
köld Tap Faucets.....	56-57
köld Chill Glycol Chillers.....	58-59
köld Seal Tubing.....	60-61
FOB Detector	62-63
Regulators	64-65
Gas Blenders	66-67
BreezeR Draft Dispenser	68-69
Breeze Draft Dispenser	70-71

□ CED 8000 □ CED 9000



CED 8000



CED 9000

Lancer's **Cold Carbonated Dispensers (CCD)**, are designed using the highest quality materials and proven technology providing our customers with consistent drink quality.

Features

- Stainless Steel cabinet construction exterior and interior
- Removable refrigeration deck
- Available with 5, 6, or 8 post-mix dispensing valves
- All valves can be serviced independently
- Insulation is CFC free, 0 GWP structural foam
- Flex manifold configuration for multiple non-carbonated drinks
- Consistent cold carbonation with built in carbonator
- All installation from front of unit CED 8000
- Additional louvers provides air circulation for more efficient operation
- R134A Refrigerant
- Available in medium and large formats
- Key Lock Switch
- Lancer Electronic Ice Bank Control

Accessories and Options

CED 8000

- Lighted Marquee
- Air Filter
- 3-way Back Block

CED 9000

- Shrouded Cabinet with Lighted Marquee

Certified by these agencies:



CUSTOMER SERVICE

Should you require more information about our products, please do not hesitate to contact our customer service team at custserv@lancerworldwide.com.



WARRANTY

For warranty specifics by product, contact your Lancer Sales Representative. Equipment design and/or specifications are subject to change without notice.

CCD Series – Cold Carbonated Dispensers

□ CED 8000 □ CED 9000

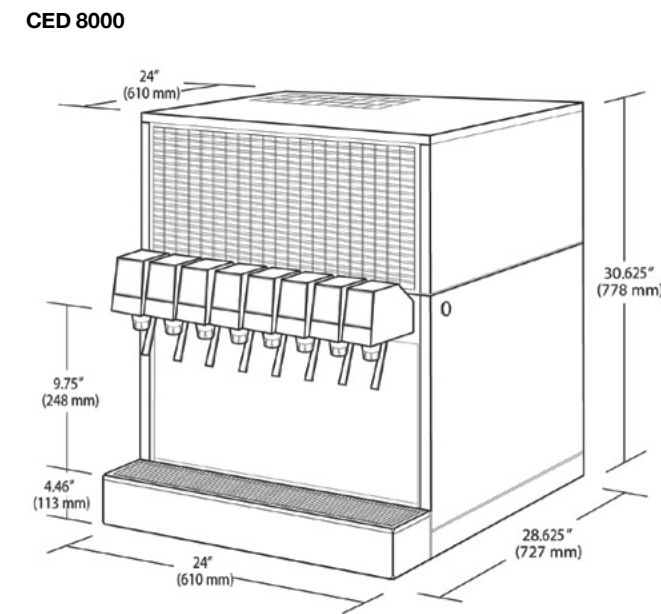

Flex Manifold Configuration

8 Valve: 3-5

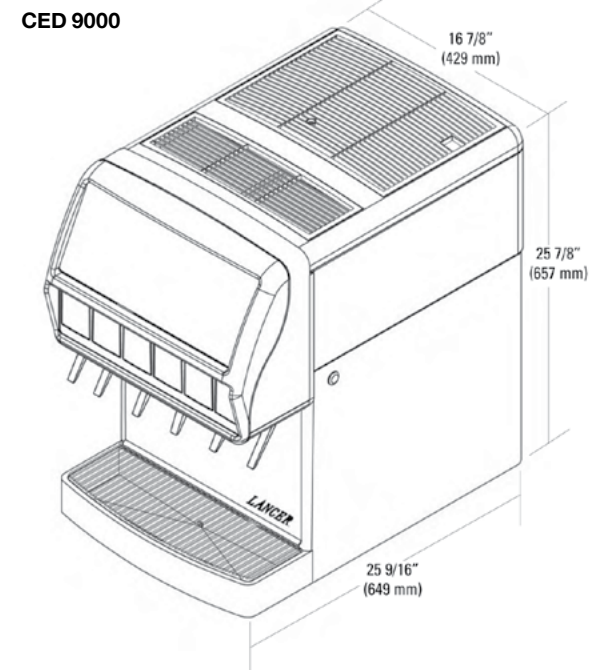

Flex Manifold Configuration

5 Valve: 3-2
6 Valve: 3-3

Dimensions

CED 8000 - 30.625" H x 24" W x 28.625" D
(778 mm H x 610 mm W x 727 mm D)
CED 9000 - 25.875" H x 16.865" W x 25.562" D
(657 mm H x 428 mm W x 649 mm D)

Weight

CED 8000 - Empty: 220 lbs (99.8kg) - Operating: 386 lbs (175 kg)
Shipping: 267 lbs (121 kg)
CED 9000 - Empty: 146 lbs (66.2 kg) - Operating: 237 lbs (108 kg)
Shipping: 160 lbs (72.6 kg)

Ice

CED 8000 - Capacity: 55 lbs (25 kg)
CED 9000 - Capacity: 25-28 lbs (11.3 - 12.7 kg)

Electrical

CED 8000 - 115V/60Hz, 14 Amps - 230V/50Hz, 7 Amps
CED 9000 - 115V/60Hz, 9 Amps - 230V/50Hz, 4.5 Amps

Compressor

CED 8000 - 3/4 hp
CED 9000 - 1/3 hp

Motors

CED 8000 - Agitator: 25 w - Condenser fan: 35 w
CED 9000 - Agitator: 25 w - Condenser fan: 9 w

□ Delta 600



Lancer's **Delta 600** is the Next Generation Counter Electric Dispenser - reliability, together with a clean, green refrigerant. A great option for carbonated as well as alternative beverages.

Features

- In compliance with green initiatives, the **Delta 600** uses R290 refrigerant making fountain even greener
- Consistent cold carbonation
- Fully louvered top provides air circulation for more efficient operation
- Stainless steel construction exterior and interior
- Improved insulation is CFC free, 0 GWP (Global Warming Potential) structural foam
- Fittings:
Carbonated Water Inlet: 3/8"(9.5 mm) male flare
Plain Water inlet: 3/8"(9.5 mm) male barb
Syrup inlets: 1/4"(6.35 mm) male barb
- LEV® Valves standard, other valves available upon request
- Key Lock Switch
- Lancer Electronic Ice Bank Control

Accessories and Options

- Shrouded Merchandiser
- R134a Refrigerant

Certified by these agencies:



CUSTOMER SERVICE

Should you require more information about our products, please do not hesitate to contact our customer service team at custserv@lancerworldwide.com.



WARRANTY

For warranty specifics by product, contact your Lancer Sales Representative. Equipment design and/or specifications are subject to change without notice.

Delta 600 Cold Carbonated Dispenser

□ Delta 600

Delta 600 with optional shrouded merchandiser

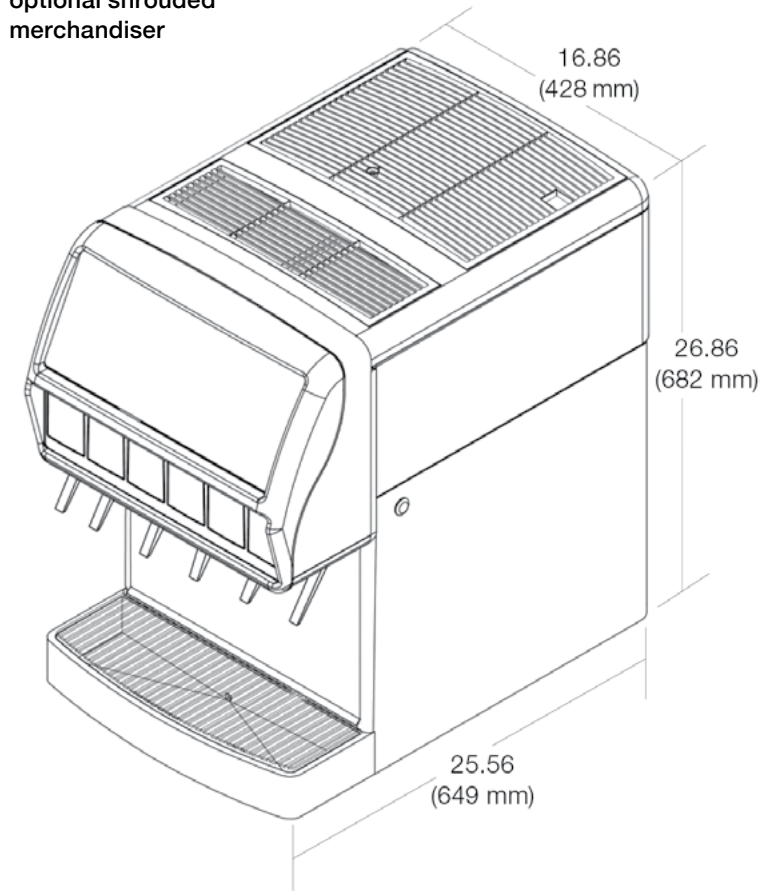

Distinctive Design

- Flex Manifold Configuration



Dimensions

26.86" H x 16.86" W x 25.56" D
(682 mm H x 428 mm W x 649 mm D)

Weight

Empty: 160 lbs (73 kg)
Operating: 240 lbs (109 kg)
Shipping: 180 lbs (82 kg)

Ice

Capacity: 22-24 lbs (10- 11.8 kg)

Electrical

115V/60Hz, 8 Amps
230V/50Hz, 4.0 Amps

Compressor

407W (230V/50Hz)
285W (115V/60Hz)

Delta 600 Cold Carbonated Dispenser

CED 1500



Lancer's **Counter Electric Dispensers (CED)** are designed using the highest quality materials and proven technology providing our customers with consistent drink quality.

Features

- Stainless steel construction exterior and interior
- Available with 4, 5, 6, or 8 post-mix dispensing valves that can be serviced independently
- Insulation is CFC free, 0 GWP, structural foam
- All installation from front of unit
- CFC free, R134A refrigerant
- Flex manifold configuration for multiple non carbonated drinks
- Syrup & soda inlets: 3/8" (9.5 mm) male barb
All syrup lines chilled
- LEV® valves standard, other valves available upon request
- Key lock switch
- Lancer electronic ice bank control
- 24V secondary transformer
- Available in small, medium and large formats
- External carbonator needed

Accessories and Options

- Lighted Marquee
- Leg Kit

Certified by these agencies:



CUSTOMER SERVICE

Should you require more information about our products, please do not hesitate to contact our customer service team at custserv@lancerworldwide.com.



WARRANTY

For warranty specifics by product, contact your Lancer Sales Representative. Equipment design and/or specifications are subject to change without notice.

CED Series – External Carbonation

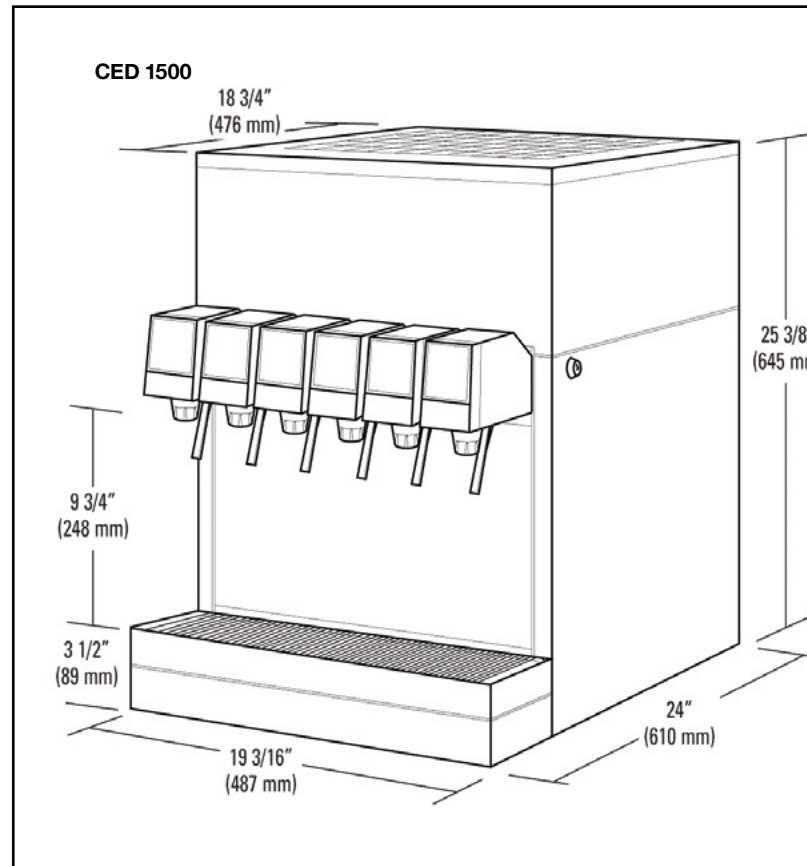

Distinctive Design

All valves are post-mix dispensing and can be serviced independently

- **CED 500** - 4 Valves Flooded 4-0 Split 2-2
- **CED 1500** - 5 valves (2-2-1)
6 valves (3-2-1)
- **CED 1500E** - 5 valves (2-2-1)
6 valves (3-2-1)
- **CED 2500** - 6 valves (3-2-1)
8 valves (3-1-1-3)

Dimensions

- CED 500 - 27.5" H x 10.375" W x 25.25" D (699 mm H x 264 mm W x 641 mm D)
- CED 1500 - 25.375" H x 19.187" W x 24" D (645 mm H x 487 mm W x 610 mm D)
- CED 2500 - 31.25" H x 26" W x 27.125" D (794 mm H x 660 mm W x 689 mm D)

Weight

- CED 500 - Empty: 89 lbs (40kg) - Operating: 131 lbs (59 kg)
Shipping: 108 lbs (49 kg)
- CED 1500 - Empty: 130 lbs (59 kg) - Operating: 230 lbs (104 kg)
Shipping: 170 lbs (77 kg)
- CED 2500 - Empty: 209 lbs (95 kg) - Operating: 376 lbs (171 kg)
Shipping: 257 lbs (117 kg)

Ice

- CED 500 - Bank Weight: 17 lbs (7.7 kg)
- CED 1500 - Bank Weight: 30 lbs (13.6 kg)
- CED 2500 - Bank Weight: 55 lbs (25 kg)

Electrical

- CED 500 - 115V/60Hz, 7 Amps - 230V/50Hz, 3.3 Amps
- CED 1500 - 115V/60Hz, 7.8 Amps - 230V/50Hz, 4.5 Amps
- CED 2500 - 115V/60Hz, 12 Amps - 230V/50Hz, 4.3Amps

Water Bath

- CED 500 - Capacity: 5 gal (19L)
- CED 1500 - Capacity: 12 gal (45L)
- CED 2500 - Capacity: 21 gal (80 L)

Compressor

- CED 500 - 1/4 hp
- CED 1500 - 1/3 hp
- CED 2500 - 3/4 hp

Motors

- CED 500 - Agitator: 15 w - Condenser fan: 9 w
- CED 1500 - Agitator: 25 w - Condenser fan: 9 w
- CED 2500 - Agitator: 25 w - Condenser fan: 35 w

CED 1500 Ambient



Lancer's **Counter Electric Dispensers (CED)** are designed using the highest quality materials and proven technology providing our customers with consistent drink quality. The ambient non-carbonated models are great for the juices and teas your customers enjoy.

Features

- Stainless steel construction exterior and interior
- Available with 4, 5 or 6 post-mix dispensing valves that can be serviced independently
- Insulation is CFC-free, 0 GWP, structural foam
- All installation from front of unit
- CFC-free, R134A refrigerant
- All syrup lines ambient
- Syrup & water inlets: 3/8" (9.5 mm) male barb
- LEV® valves standard, other valves available upon request
- Key lock switch
- Lancer electronic ice bank control
- 24V secondary transformer

Accessories and Options

- Lighted Marquee
- Leg Kit

Certified by these agencies:



CUSTOMER SERVICE

Should you require more information about our products, please do not hesitate to contact our customer service team at custserv@lancerworldwide.com.



WARRANTY

For warranty specifics by product, contact your Lancer Sales Representative. Equipment design and/or specifications are subject to change without notice.

CED Series – Ambient Non-Carbonated

CED 1500 Non Carbonated

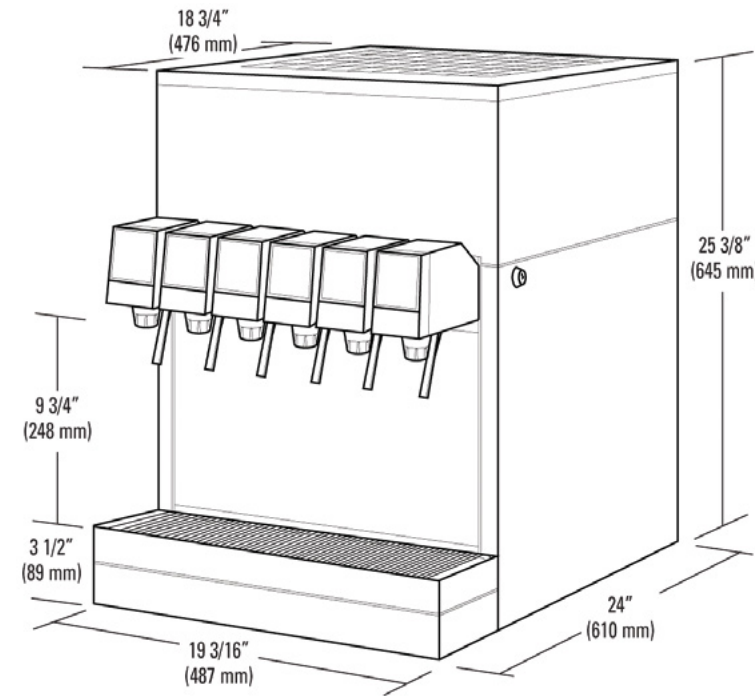

Distinctive Design

Valves are post-mix dispensing and can be serviced independently

- 4 valves (4-0)
- 5 valves (2-2-1)
- 6 valves (3-2-1)

Dimensions

- CED 500 - 27.5" H x 10.375" W x 25.25" D (699 mm H x 264 mm W x 641 mm D)
- CED 1500 - 25.375" H x 19.187" W x 24" D (645 mm H x 487 mm W x 610 mm D)

Weight

- CED 500 - Empty: 89 lbs (40kg) - Operating: 131 lbs (59 kg) Shipping: 108 lbs (49 kg)
- CED 1500 - Empty: 130 lbs (59 kg) - Operating: 230 lbs (104 kg) Shipping: 170 lbs (77 kg)

Ice

- CED 500 - Bank Weight: 17 lbs (7.7 kg)
- CED 1500 - Bank Weight: 30 lbs (13.6 kg)

Electrical

- CED 500 - 115V/60Hz, 7 Amps - 230V/50Hz, 3.3 Amps
- CED 1500 - 115V/60Hz, 7.8 Amps - 230V/50Hz, 4.5 Amps

Water Bath

- CED 500 - Capacity: 5 gal (19L)
- CED 1500 - Capacity: 12 gal (45L)

Compressor

- CED 500 - 1/4 hp
- CED 1500 - 1/3 hp

Motors

- CED 500 - Agitator: 15 w - Condenser fan: 9 w
- CED 1500 - Agitator: 25 w - Condenser fan: 9 w

- 500 (2cir)
- 1500 (4cir)
- 1500 (6cir)
- 2500 (4cir)
- 2500 (9cir)



CED 1500 Prechiller

Lancer's **Counter Electric Dispensers (CED) Prechillers** are designed using the highest quality materials and proven technology to keep your ice supply servable for longer hours.

Features

- Full insulated ice storage cabinet that prevents melting of ice
- Stainless steel construction exterior and interior
- CFC free refrigerant
- Lancer Electronic Ice Bank Control
- Stainless steel inlet and outlet labeled 3/8" (9.5 mm) barb

Certified by these agencies:



WARRANTY

For warranty specifics by product, contact your Lancer Sales Representative. Equipment design and/or specifications are subject to change without notice.

CUSTOMER SERVICE

Should you require more information about our products, please do not hesitate to contact our customer service team at custserv@lancerworldwide.com.

CED Prechiller Series Ice Storage Chillers

- 500 (2cir)
- 1500 (4cir)
- 1500 (6cir)
- 2500 (4cir)
- 2500 (9cir)

CED Prechiller 2500

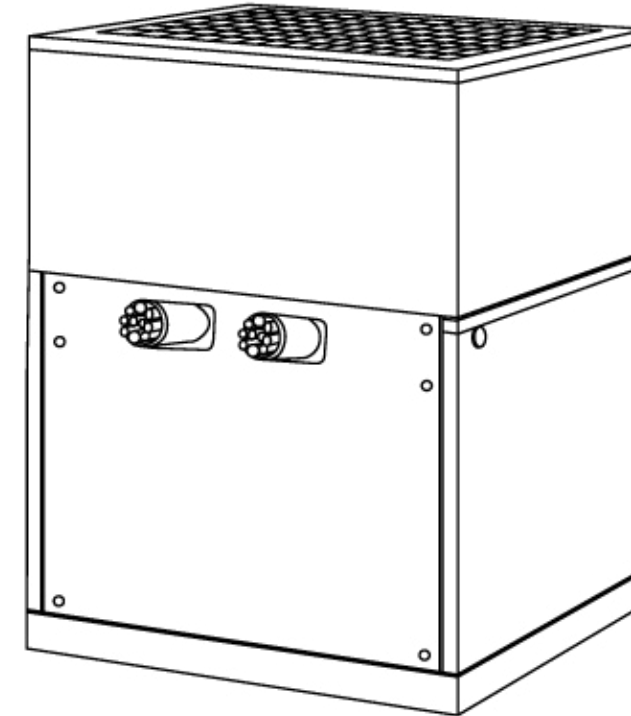

Distinctive Design

Circuits are used for non carbonated water, carbonated water or syrup.

- CED Prechiller 500 - 2 circuits
- CED Prechiller 1500 - 4 circuits
- CED Prechiller 1500 - 9 circuits
- CED Prechiller 2500 - 4 circuits
- CED Prechiller 2500 - 9 circuits

Dimensions

- CED Prechiller 500 - 23.5" H x 10.375" W x 19.688" D
(597 mm H x 264 mm W x 500 mm D)
- CED Prechiller 1500 - 25.375" H x 19.188" W x 19.125" D
(645 mm H x 487 mm W x 486 mm D)
- CED Prechiller 2500 - 31.25" H x 26" W x 22" D
(794 mm H x 660 mm W x 559 mm D)

Weight

- CED Prechiller 500 - With water: 145 lbs (66 kg)
Shipping: 108 lbs (49 kg)
- CED Prechiller 1500 - With water: 261 lbs (118 kg)
Shipping: 150 lbs (68 kg)
- CED Prechiller 2500 - With water: 479 lbs (217 kg)
Shipping: 300 lbs (136 kg)

Electrical

- CED Prechiller 500 - 115V/60Hz, 7 Amps - 230V/50Hz, 3.3 Amps
- CED Prechiller 1500 - 115V/60Hz, 7.8 Amps - 230V/50Hz, 4.5 Amps
- CED Prechiller 2500 - 115V/60Hz, 12 Amps - 230V/50Hz, 4.3 Amps

Compressor

- CED Prechiller 500 - 1/4 hp
- CED Prechiller 1500 - 1/3 hp
- CED Prechiller 2500 - 3/4 hp

Motors

- CED Prechiller 500 - Agitator: 15 w - Condenser fan: 9 w
- CED Prechiller 1500 - Agitator: 25 w - Condenser fan: 9 w
- CED Prechiller 2500 - Agitator: 25 w - Condenser fan: 35 w

CED Prechiller Series Ice Storage Chillers

- IBD 22 □ IBD 25 □ IBD 30 □ IBD 44 □ 4500+

IBD 30



4500+



Accessories and Options

Ice Maker Compatibility

- Accepts 22", 25", 30" & 44" wide ice makers (adapters may be required)
- Manual front load tee chute
- Variable automatic agitation timer
- Pellet capable dispense is available (specifications on request)

Certified by these agencies:



CUSTOMER SERVICE

Should you require more information about our products, please do not hesitate to contact our customer service team at custserv@lancerworldwide.com.

The **IBD** is Lancer's #1 selling self-serve dispenser. Hard plumbed syrup and water lines deliver excellent icy cold drinks. Versatile valve configurations and a portion control option allow for easy beverage cost monitoring. Topped with a compelling wraparound display, the IBD is a favorite.

Features

- Illuminated interchangeable front graphics
- High capacity ice storage bin
- Stainless steel construction; exterior and interior
- High capacity drip tray helps avoid safety hazards and drink station cleanup from spills
- Unique hex drive ice agitation and dispense drive system
- Multiple valve configurations available for self-serve and portion control operation
- Fully insulated storage bin and drip tray to control condensation and avoid moisture related safety hazards
- Front and rear plumbing access for installation flexibility
- Syrup & soda inlets: 3/8" (9.5 mm) male barb
- LEV® valves standard, other valves available upon request
- Key lock switch



WARRANTY

For warranty specifics by product, contact your Lancer Sales Representative. Equipment design and/or specifications are subject to change without notice.

IBD 4500 Series Ice Beverage Dispensers

- IBD 22 □ IBD 25 □ IBD 30 □ IBD 44 □ 4500+

IBD 4500 Series Ice Beverage Dispensers

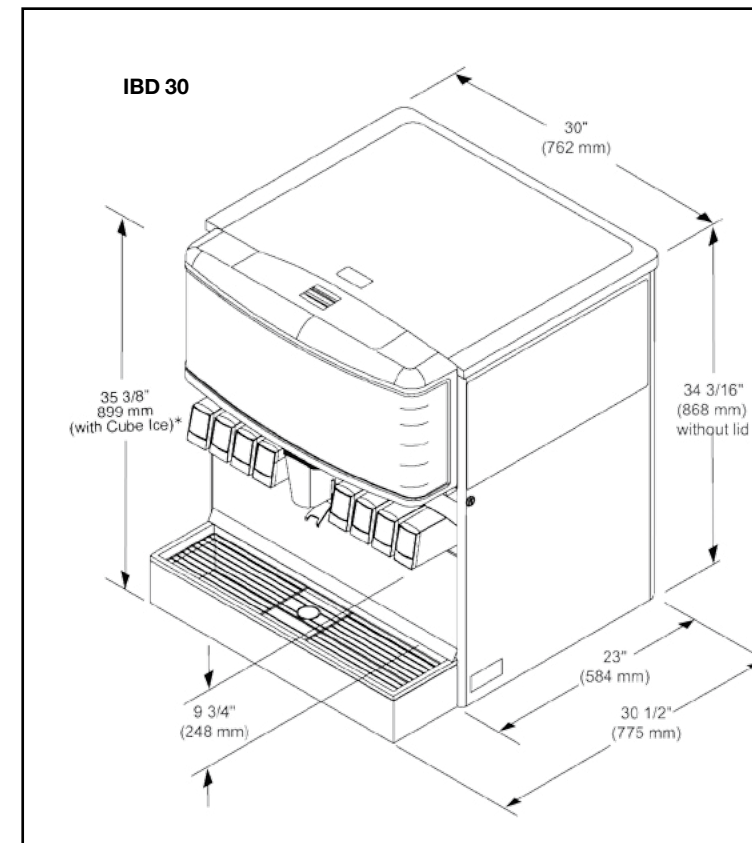

Distinctive Design

- **IBD 22** - 6 valves (3-2-1)
- **IBD 25** - 8 valves (3-1-1-3)
- **IBD 30** - 8 valves (3-1-1-3)
10 valves (3-1-2-1-3)
Cube or Nugget Ice
- **IBD 44** - 12 valves (3-2-1-1-2-3)
- two ice chutes
- **4500+** - 12 valves (3-2-1-1-2-3)
- two ice chutes

Dimensions

- IBD 22 - 35.375" H x 22" W x 30.5" D (899 mm H x 559 mm W x 775 mm D)
- IBD 25 - 35.375" H x 25" W x 30.5" D (899 mm H x 635 mm W x 775 mm D)
- IBD 30 - 35.375" H x 30" W x 30.5" D (899 mm H x 762 mm W x 775 mm D)
- IBD 44 - 35.375" H x 44" W x 30.5" D (899 mm H x 1118 mm W x 775 mm D)
- 4500+ - 35.375" H x 44" W x 30.5" D (899 mm H x 1118 mm W x 775 mm D)

Space Required

- IBD 22 - 24" W x 31.5" D - (610mm W x 800 mm D)
- IBD 25 - 27" W x 31.5" D - (686 mm W x 800 mm D)
- IBD 30 - 32" W x 31.5" D - (813 mm W x 800 mm D)
- IBD 44 - 46" W x 31.5" D - (1168 mm W x 800 mm D)
- 4500+ - 46" W x 31.5" D - (1168 mm W x 800 mm D)

Height: Allow sufficient clearance for manually filling with ice or refer to ice maker recommendation for top clearance.

Weight

- IBD 22 - With Ice: 405 lbs (184kg) - Shipping: 255 lbs (116kg)
- IBD 25 - With Ice: 460 lbs (208kg) - Shipping: 290 lbs (132kg)
- IBD 30 - With ice: 525lbs (238 kg) - Shipping: 305 lbs (138 kg)
- IBD 44 - With ice: 760 lbs (345 kg) - Shipping: 460 lbs (209 kg)
- 4500+ - With ice: 760 lbs (345 kg) - Shipping: 460 lbs (209 kg)

Ice

- IBD 22 - Capacity: 180 lbs (82kg) - Dispensable: 150 lbs (68kg)
- IBD 25 - Capacity: 205 lbs (93kg) - Dispensable: 160 lbs (73kg)
- IBD 30 - Capacity: 250 lbs (113 kg) - Dispensable: 175 lbs (79 kg)
- IBD 44 - Capacity: 360 lbs (163 kg) - Dispensable: 300 lbs (136 kg)
- 4500+ - Capacity: 360 lbs (163 kg) - Dispensable: 300 lbs (136 kg)

Electrical

- IBD 22 - 115V/60Hz, 3Amps - 230V/50Hz, 1.5Amps
- IBD 25 - 115V/60Hz, 3Amps - 230V/50Hz, 1.5Amps
- IBD 30 - 115V/60Hz - 230/50Hz
- IBD44 - 115V/60Hz - 230/50Hz
- 4500+ - 220-240V, 50/60Hz, 1.5Amps

Requires two electrical outlets for unit and LCD merchandiser

Flavor Select 30



The Flavor Select (FS) offers up to 200 flavor combinations featuring state-of-the-art cold carbonation technology the FS provides a consistently pleasing drink experience. Enhanced ice dispensing capability allows customers to dispense cube or cubelet ice, on demand.

Features

- Cold carbonation
- “Lite Touch” draws attention to your more profitable fountain section
- “Air Mix” nozzles blend syrup and water in midair for consistent drink delivery
- Illuminated, easily interchangeable merchandiser
- Large capacity, removable drip tray & cup rest
- Three ice bin fill options: ice maker production, manual loading, or both
- Cubelet ice capable dispense is available; specifications on request
- Dosing or blending available for bonus flavors
- Field configurable
- Front connection for products
- Syrup & soda inlets: 3/8” (9.5 mm) male barb
- Lancer Flow Control Valves (LFCV)
- Key lock switch



WARRANTY

For warranty specifics by product, contact your Lancer Sales Representative. Equipment design and/or specifications are subject to change without notice.

Accessories and Options

- ADA Kit
- Splash Guards
- Extended Splash Plate (No drip tray)

Flavor Select 30” only
LCD Digital Merchandiser

Certified by these agencies:



CUSTOMER SERVICE

Should you require more information about our products, please do not hesitate to contact our customer service team at custserv@lancerworldwide.com.

Flavor Select Ice Beverage Dispensers

Flavor Select 30

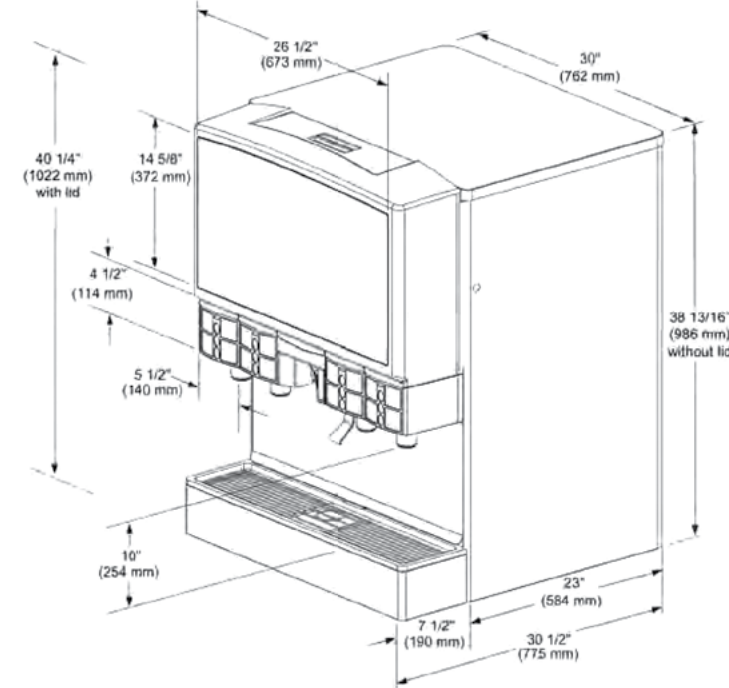

Distinctive Design

- **FS22** - eight brands (over 50 flavor possibilities) - Add up to six bonus flavors
- **FS30** - up to 16 brands (over 100 flavor possibilities) - Add up to 12 bonus flavors
- **FS44** - up to 16 brands (over 100 flavor possibilities) - Add up to 12 bonus flavors - two ice chutes
- **FS60** - up to 32 brands (over 200 flavor possibilities) - Add up to 24 bonus flavors - two ice chutes

Dimensions

- Flavor Select 22 - 40.25" H x 22" W x 30.5" D (1022 mm H x 558 mm W x 775 mm D)
- Flavor Select 30 - 40.25" H x 30" W x 30.5" D (1022 mm H x 762 mm W x 775 mm D)
- Flavor Select 44 - 40.25" H x 44.875" W x 30.5" D (1022 mm H x 1140 mm W x 775 mm D)
- Flavor Select 60 - 40.25" H x 60.75" W x 30.5" D (1022 mm H x 1543 mm W x 775 mm D)

Weight

- Flavor Select 22 - Without Ice: 280 lbs (127kg) With Ice: 480 lbs (218kg) Shipping: 310 lbs (141kg)
- Flavor Select 30 - Without ice: 320 lbs (145 kg) With ice: 610 lbs (281 kg) Shipping: 356 lbs (161 kg)
- Flavor Select 44 - Without ice: 620 lbs (282 kg) With ice: 1020 lbs (464 kg) Shipping: 710 lbs (323 kg)
- Flavor Select 60 - Without Ice: 640 lbs (290 kg) With Ice: 1100 lbs (500 kg) Shipping: 712 lbs (322 kg)

Ice

- Flavor Select 22 - Capacity: 200 lbs (91kg) Dispensable: 170 lbs (77kg)
- Flavor Select 30 - Capacity: 290 lbs (132 kg) Dispensable: 215 lbs (98 kg)
- Flavor Select 44 - Capacity: 400 lbs (181 kg) Dispensable: 340 lbs (154 kg)
Note: This dispenser contains two independent ice bins that utilize two 22" ice makers and two 22" ice maker adapters. These bins can also be manually filled.
- Flavor Select 60 - Capacity: 580 lbs (264 kg) Dispensable: 430 lbs (195 kg)
Note: This dispenser contains two independent ice bins that utilize two 30" ice makers and two 30" ice maker adapters. These bins can also be manually filled.

Electrical

- Flavor Select 22 - 220-240V, 50/60Hz, 3.5Amps
- Flavor Select 30 - 115V/60Hz, 7Amps
- Flavor Select 44 - (2) 120V/60Hz, 14Amps
- Flavor Select 60 - (2) 115V/60Hz, 15Amps

Water

- Flavor Select 22 - Filtered water 50 psi min
- Flavor Select 30 - Filtered water 50 psi min
- Flavor Select 44 - Filtered water 50 psi min
- Flavor Select 60 - Filtered water 50 psi min
Note: water booster recommended

Flavor Select Ice Beverage Dispensers

Sensation 44



With the **Sensation 44** you can offer your customers multiple beverage options including the ability to dispense cubed or chewable ice, 12 different flavor options and up to eight bonus shots. Available in stainless steel or matte black with an option to have enhanced connectivity with a 32" diagonal video merchandiser.

Features

- Dispenses cubelet ice without a change to the equipment
- High capacity drip tray reduces clean up and avoids safety issues due to spills
- Serviceable parts are located on the front of the unit for easy access
- Durable hex drive ice agitation system for trouble-free operation and long service life
- Multiple valve options available for self-serve applications
- Portion control valves available to control beverage costs on Sensation 30
- Stainless steel construction exterior and interior
- High capacity ice storage bin
- Key lock switch

Accessories and Options

- Sensation 30:**
Medallion Merchandiser
- Sensation 44:**
LCD Merchandiser
Stainless Steel or Matte Black exterior
Flavor Shot Module with up to 8 bonus flavors
Dual Ice Divider
Extended Splashplate

Certified by these agencies:



CUSTOMER SERVICE

Should you require more information about our products, please do not hesitate to contact our customer service team at custserv@lancerworldwide.com.



WARRANTY

For warranty specifics by product, contact your Lancer Sales Representative. Equipment design and/or specifications are subject to change without notice.

Sensation Cold Carbonation Ice Beverage Dispensers

Sensation 44

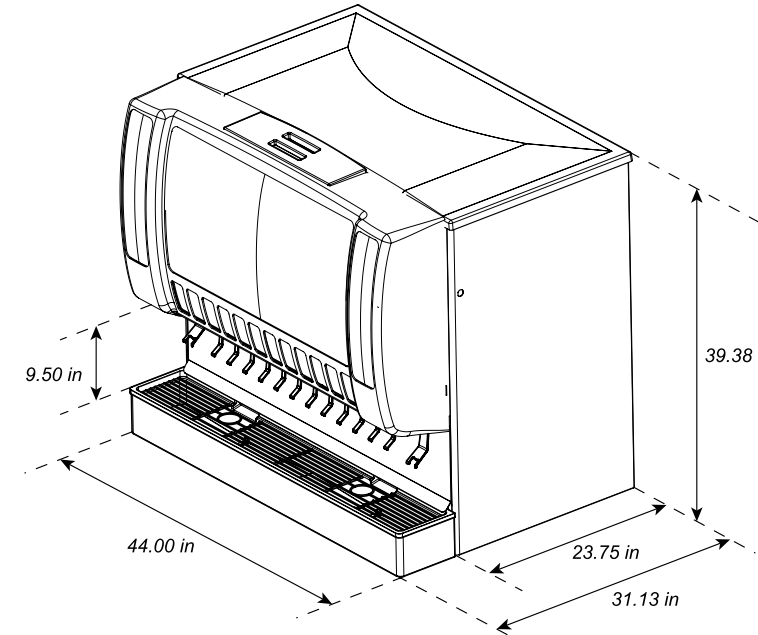

Distinctive Design

- No more drip trays full of ice, ice on the floor, wet floor signs, snowballing, ice bridging and unnecessary service calls!
- Dispenses any kind of extruded ice
- Cold carbonation for crisp, fresh tasting beverages.
- Environmentally friendly LED lighting improves presentation
- Plumbing access front and rear for installation flexibility

Dimensions

Sensation 30 - 37.25" H x 30" W x 31" D
(946 mm H x 762 mm W x 787 mm D)
Sensation 44 - 39.375" H x 44" W x 31" D
(1000 mm H x 1118 mm W x 787 mm D)

Space Required

Sensation 30 - Width: 32" (813 mm)
Depth: 39" (991 mm)
Height: Allow sufficient clearance for manually filling with ice or refer to ice maker recommendation for top clearance.
Sensation 44 - Width: 46" (1168.4 mm)
Depth: 40" (1016 mm)
Height: Allow sufficient clearance for manually filling with ice or refer to ice maker recommendation for top clearance.

Weight

Sensation 30 - With ice: 525 lbs (238 kg)
Shipping: 335 lbs (152 kg)
Sensation 44 - With ice: 745 lbs (338 kg)
Shipping: 585 lbs (265 kg)

Ice

Sensation 30 - Capacity: 250 lbs (113 kg)
Dispensable: 185 lbs (84 kg)
Accepts 30" and 22" wide ice makers
(adapters may be required)
Sensation 44 - Capacity: 312 lbs (142 kg)
Dispensable: 255 lbs (116 kg)
Accepts 30" and 22" and 44" wide ice makers
(adapters may be required)

Electrical

Sensation 30 - 220-240V, 50/60 Hz, 1.5Amps
Sensation 44 - 220-240V, 50/60 Hz, 3Amps

Fittings for both units

Syrup & Soda Inlets: 3/8" (9.5 mm) male barb

Valves

Sensation 30 - LEV® or VersaPour
Sensation 44 - LEV® or VersaPour

Flex Manifold Configuration

Sensation 30 - 8 Valve: 3-1-1-3
Sensation 44 - 12 Valve: 3-1-1-1-1-1-3

Sensation Cold Carbonation Ice Beverage Dispensers

□ TwinPour44



TWIN POUR
with Lancer Link™

Two-time International award-winning **Twin Pour™** features dual touch screens, along with two versatile ice dispensers and a programmable and wifi enabled LCD video merchandiser. With up to 266 flavor combinations, including carbonated and non-carbonated, and our proprietary FluidicFlow™ dispensing technology ensures there is no flavor transfer, for the perfect drink every time.

Features

- Now with Lancer Link™
- Up to 266 flavor combinations, including carbonated and non-carbonated water
- Serve two customers at once
- Two 7" LED touch screens
- Two versatile ice dispense points for all ice types; including chewable ice
- Built in redundancy ensures maximum uptime
- Programmable and WIFI enabled LCD merchandiser
- Programmable LED target lighting
- LFCV 4.0 oz. (multi flavor)
- 2 Key lock switches
- Pump Deck and Ice Adaptor included



Accessories and Options

- LCD Merchandiser Kit
- Extended Splash Plate
- Dual Ice Divider

Certified by these agencies:



CUSTOMER SERVICE

Should you require more information about our products, please do not hesitate to contact our customer service team at custserv@lancerworldwide.com.



WARRANTY

For warranty specifics by product, contact your Lancer Sales Representative. Equipment design and/or specifications are subject to change without notice.

TwinPour Cold Carbonation Ice Beverage Dispenser

□ TwinPour44

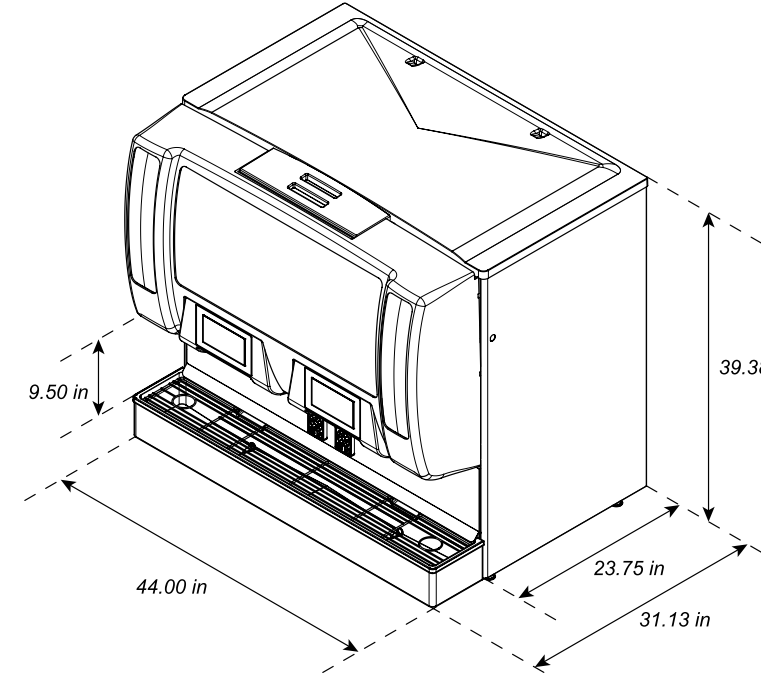

Distinctive Design

- Cold Carbonation
- Pick off tubes
1 plain water
1 carbonated water

Dimensions

Height: 39.375" (1000.1 mm)
Width: 44" (1117.6 mm)
Depth: 31" (787.4 mm)

Space Required

Width: 46" (1168.4 mm)
Depth: 40" (1016 mm)
Height: Allow sufficient clearance for manually filling with ice or refer to ice maker recommendation for top clearance.

Electrical

115V/60Hz, 6Amps
220-240V, 50/60 Hz, 3Amps

Weight

With Ice: 745 lbs (337.9 kg)
Shipping: 585 lbs (265 kg)

Ice

Capacity: 312 lbs (142 kg)
Dispensable: 255 lbs (116 kg)
Accepts 30" and 22" and 44" wide ice makers (adapters may be required)

Fittings

Soda Inlets: 3/8" (9.5mm) male barb
Syrup Inlets: 3/8" (9.5mm) male barb

Flex Manifold Configuration

Total carb / non carb flexibility
Up to 24 brands
(10 chilled / 2 ambient per nozzle)
Up to 8 bonus Flavors (4 per nozzle)

TwinPour Cold Carbonation Ice Beverage Dispenser

ICDI 2300 8vl



Standard Performance Ice Cooled Drop In Dispensers (ICDI)

are designed using the highest quality materials and proven technology providing our customers with consistent drink quality.

Features

- Improved easy serviceability/cleanability
- Stainless steel construction with sealed in cold plate
- Ice bin insulated with CFC free structural foam
- Syrup & soda inlets: 3/8" (9.5 mm) male barb
- LEV® valves standard, other valves available upon request
- Key lock switch

Accessories and Options

- Conversion Stand
- Marquee
- Merchandiser
- Splash Guards
- Power Supply
- Valve Conversion Kit

Certified by these agencies:



CUSTOMER SERVICE

Should you require more information about our products, please do not hesitate to contact our customer service team at custserv@lancerworldwide.com.



WARRANTY

For warranty specifics by product, contact your Lancer Sales Representative. Equipment design and/or specifications are subject to change without notice.

Standard Performance Ice Cooled Drop In Dispensers

ICDI 2300 8vl

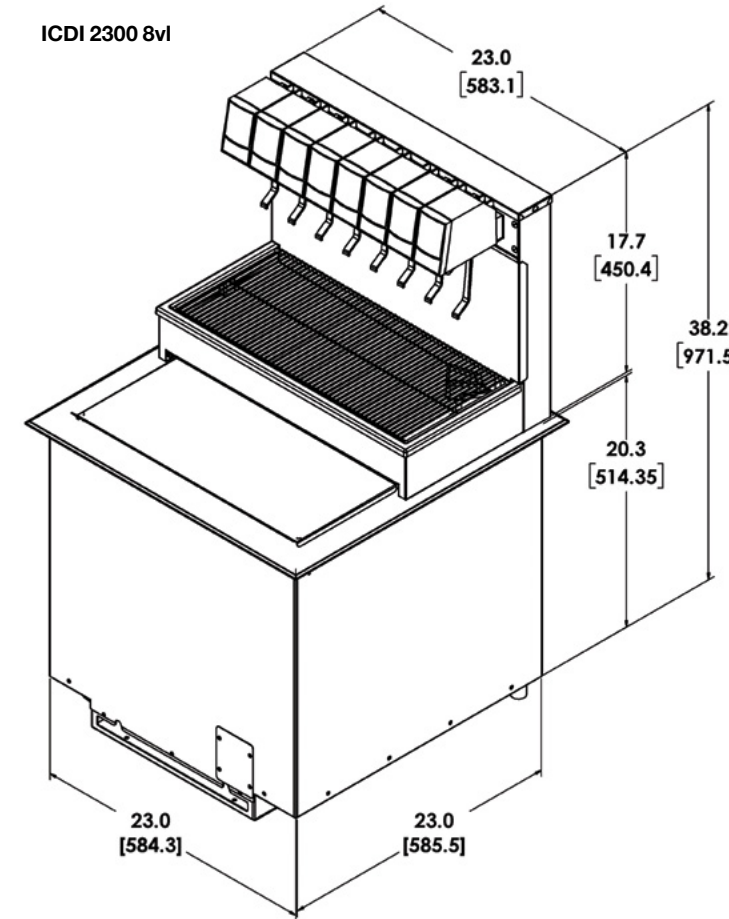

Distinctive Design

Meets or exceeds industry standards for performance

- ICDI 2200** -5 valves (2-2-1)
 6 valves (3-2-1)
 Removable splash plate and drip tray for easy cleaning

- ICDI 2300** -6 valves (2-1-1-2)
 8 valves (3-1-1-3)
 – Onsite Upgrade
 – Front Plumbing Inlets

Dimensions

- ICDI 2200 - 33.375" H x 15" W x 23" D
 (848 mm H x 381 mm W x 584 mm D)
 ICDI 2300 - 38.2" H x 23" W x 23" D
 (970 mm H x 584 mm W x 584 mm D)

Counter Cut-Out

- ICDI 2200 - 15.25" W x 23.25" D
 (387 mm W x 591 mm D)
 ICDI 2300 - 23.25" W x 23.25" D
 (591 mm W x 591 mm D)

Weight

- ICDI 2200 - Operating: 166 lbs (75 kg)
 Shipping: 175 lbs (79 kg)
 ICDI 2300 - Operating: 206 lbs (93 kg)
 Shipping: 260 lbs (118 kg)

Ice

- ICDI 2200 - Capacity: 60 lbs (27.2 kg)
 ICDI 2300 - Capacity: 100 lbs (45 kg)

Electrical

- ICDI 2200 - 115V/60Hz
 ICDI 2300 - 115V/60Hz
 220-240V/50-60Hz



ICDI 2323 8vl

High Performance Ice Cooled Drop In Dispensers (ICDI) utilize advanced engineering simulations for the coldest drinks in the industry. They exceeds all industry standards for draw capacity with flow rates up to 4.5 oz. per second.

Features

- Front plumbing inlets
- Improved easy serviceability/cleanability
- 100 % carbonation and plain water flexibility
- Stainless steel hard plumbed towers
- Easy to use switch over fitting
- Syrup & soda inlets: 3/8" (9.5 mm) male barb
- LEV® valves standard, other valves available upon request
- Key lock switch

Accessories and Options

- Conversion Stand
- Marquee
- Merchandiser
- 6 valve to 8 valve Conversion Kit
- Splash Guards
- Water Spigot
- Power Supply

Certified by these agencies:



CUSTOMER SERVICE

Should you require more information about our products, please do not hesitate to contact our customer service team at custserv@lancerworldwide.com.



WARRANTY

For warranty specifics by product, contact your Lancer Sales Representative. Equipment design and/or specifications are subject to change without notice.

High Performance Ice Cooled Drop In Dispensers

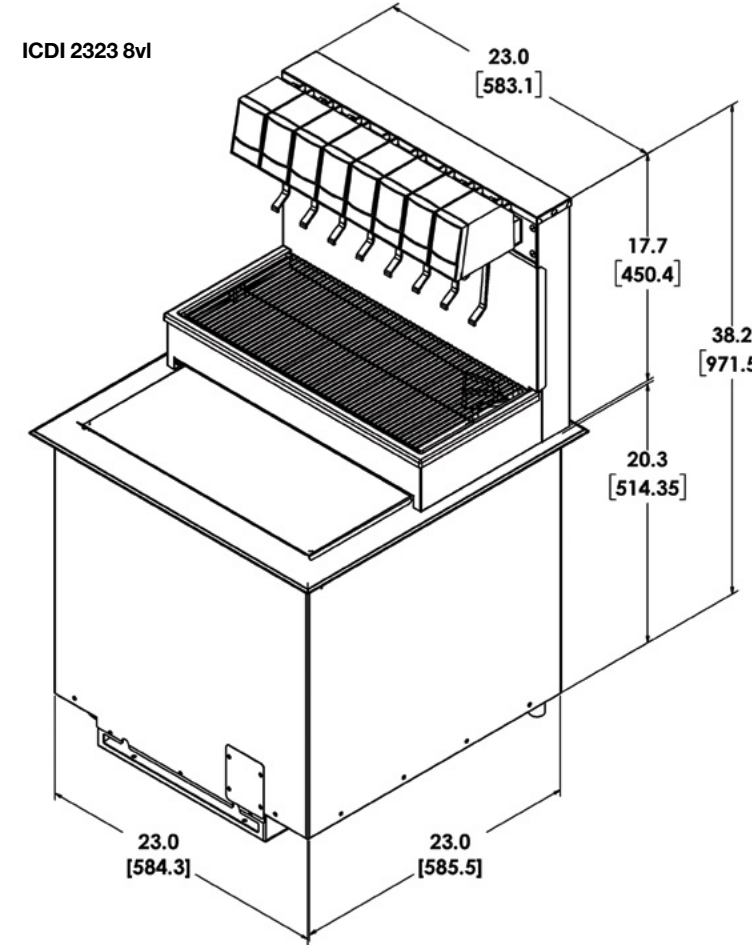

ICDI 2323 8vl

Distinctive Design

Meets or exceeds industry standards for performance

- ICDI 2323** - 6 valves (2-1-1-2)
8 valves (3-1-1-3)
10 valves (3-1-2-1-3)

Dimensions

38.2" H x 23" W x 23" D
(970 mm H x 584 mm W x 584 mm D)

Counter Cut-Out

23.25" W x 23.25" D
(591 mm W x 591 mm D)

Weight

Operating: 240 lbs (109 kg)
Shipping: 266 lbs (121 kg)

Ice

Capacity: 100 lbs (45 kg)

Electrical

115V/60Hz
220-240V/50-60Hz

ICDI 23300 8vl



The **ICDI 23300 High Performance** dispenser utilizes advanced engineering simulations for the coldest drinks in the industry. It exceeds all industry standards for draw capacity with flow rates up to 4.5 oz. per second.

Features

- Easy serviceability/cleanability
- Stainless steel construction with sealed-in cold plate
- Ice bin insulated with CFC free structural foam
- LEV® valves standard, other valves available upon request
- Key lock switch

Accessories and Options

- Conversion Stand - 23" x 30"
- Marquee
- Merchandiser
- Splash Guards
- Water Spigot
- Power Supply

Certified by these agencies:



CUSTOMER SERVICE

Should you require more information about our products, please do not hesitate to contact our customer service team at custserv@lancerworldwide.com.



WARRANTY

For warranty specifics by product, contact your Lancer Sales Representative. Equipment design and/or specifications are subject to change without notice.

ICDI 23300 High Performance Ice Cooled Drop In Dispenser

ICDI 23300 8vl

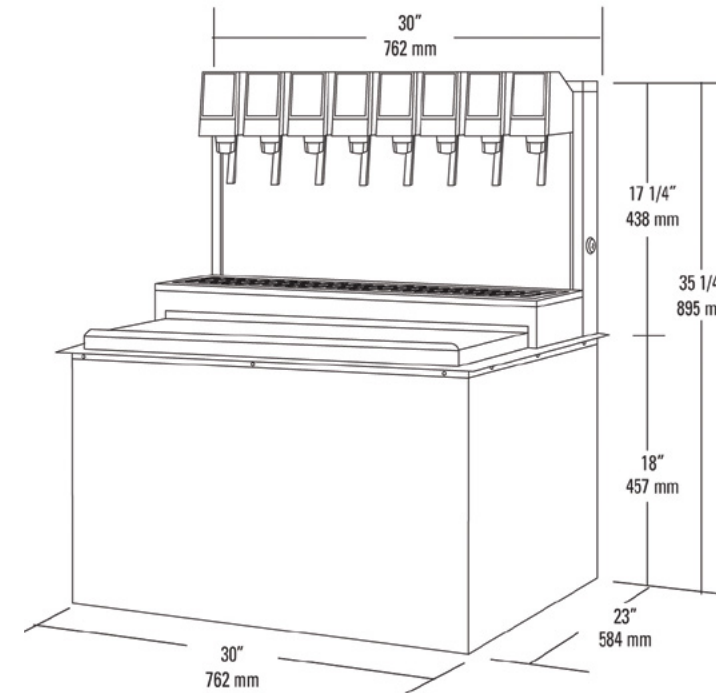

Distinctive Design

Meets or exceeds industry standards for performance

ICDI 23300 - 8 valves (3-1-1-3)
10 valves (3-1-2-1-3)

Dimensions

35.25" H x 30" W x 23" D
(895 mm H x 762 mm W x 584 mm D)

Counter Cut-Out

30.25" W x 23.25" D
(768 mm W x 591 mm D)

Weight

Operating: 370 lbs (168 kg)
Shipping: 300 lbs (136 kg)

Ice

Capacity: 130 lbs (59 kg)

Electrical

24V/60Hz

Fittings

Soda inlets: 3/8" (9.5 mm) male barb
Syrup inlets: 3/8" (9.5 mm) male barb

IC 400 Series Ice Chests

Lancer's **IC 400 Ice Chests** are designed using the highest quality materials and proven technology providing our customers with consistent drink quality.

Features

- One inch molded polyurethane structural insulation on all sides and bottom
- Stainless steel construction with or without sealed in high performance cold plate
- Drop In models available with sealed in cold plate; 1/2" drain
- Free Standing models available with sealed in cold plate
- NSF approved sliding lids



Drop In Ice Chest
22" x 15"



Free Standing Ice Chest
23" x 21"

Certified by these agencies:



CUSTOMER SERVICE

Should you require more information about our products, please do not hesitate to contact our customer service team at custserv@lancerworldwide.com.



WARRANTY

For warranty specifics by product, contact your Lancer Sales Representative. Equipment design and/or specifications are subject to change without notice.

IC 415 Drop In

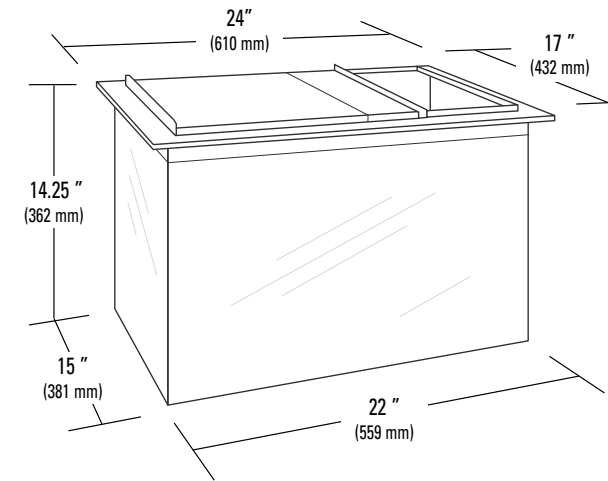

IC 421 Free Standing

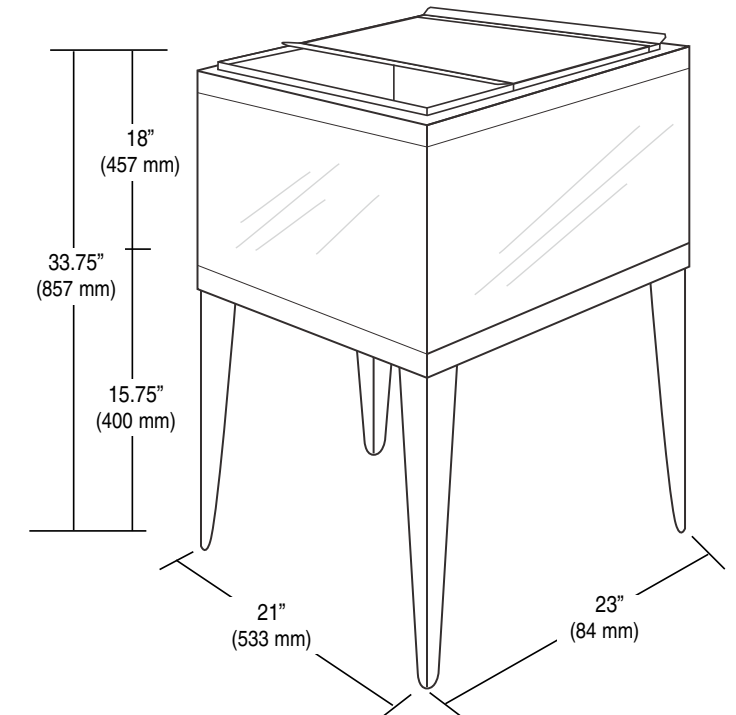

Dimensions

- IC 415 Drop In:
8 Circuit Cold Plate - 22" W x 15" D x 14.25" H
(559 mm W x 381 mm D x 362 mm H)
- IC 421 Drop In:
9 Circuit Cold Plate - 23" W x 21" D x 17.25" H
(584 mm W x 533 mm D x 438 mm H)
- IC 415 Free Standing:
8 Circuit Cold Plate - 22" W x 15" D x 14" H
(559 mm W x 381 mm D x 356 mm H)
- IC 421 Free Standing:
9 Circuit Cold Plate - 23" W x 21" D x 18" H
(584 mm W x 533 mm D x 457 mm H)

Counter Cut-out for Drop In Units

1/4" (6.35 mm) larger than dimensions

Weight

- IC 415 Drop In: Shipping weight: 90 lbs (40.8 kg)
IC 421 Drop In: Shipping weight: 114 lbs (51.7kg)
IC 415 Free Standing: Shipping weight: 90 lbs (40.8 kg)
IC 421 Free Standing: Shipping weight: 114 lbs (51.7 kg)

Ice Capacity

- IC 415 Drop In: 60 lbs (27.2 kg)
IC 421 Drop In: 100 lbs (45.4 kg)
IC 415 Free Standing: 60 lbs (27.2 kg)
IC 421 Free Standing: 100 lbs (45.4 kg)

ID 4400N 22"



ID 440 Counter Top Self Service Ice Dispensers are designed using the highest quality materials and proven technology providing our customers with consistent quality and ice dispensing.

Features

- High capacity ice storage bin
- Illuminated interchangeable front graphics
- Push and lever ice dispensing versatility
- Unique hex drive ice agitation and dispense drive system for trouble-free operation and long service life
- Heavy duty stainless steel construction, exterior and interior
- Electrical for all units:
115VAC/60Hz, 3AMPS
230VAC/50Hz, 1.5AMPS

Accessories and Options

Water Valve

Certified by these agencies:



CUSTOMER SERVICE

Should you require more information about our products, please do not hesitate to contact our customer service team at custserv@lancerworldwide.com.



WARRANTY

For warranty specifics by product, contact your Lancer Sales Representative. Equipment design and/or specifications are subject to change without notice.

ID 4400 Series Counter Top Self Service Ice Dispensers

ID 4400 Series Counter Top Self Service Ice Dispensers

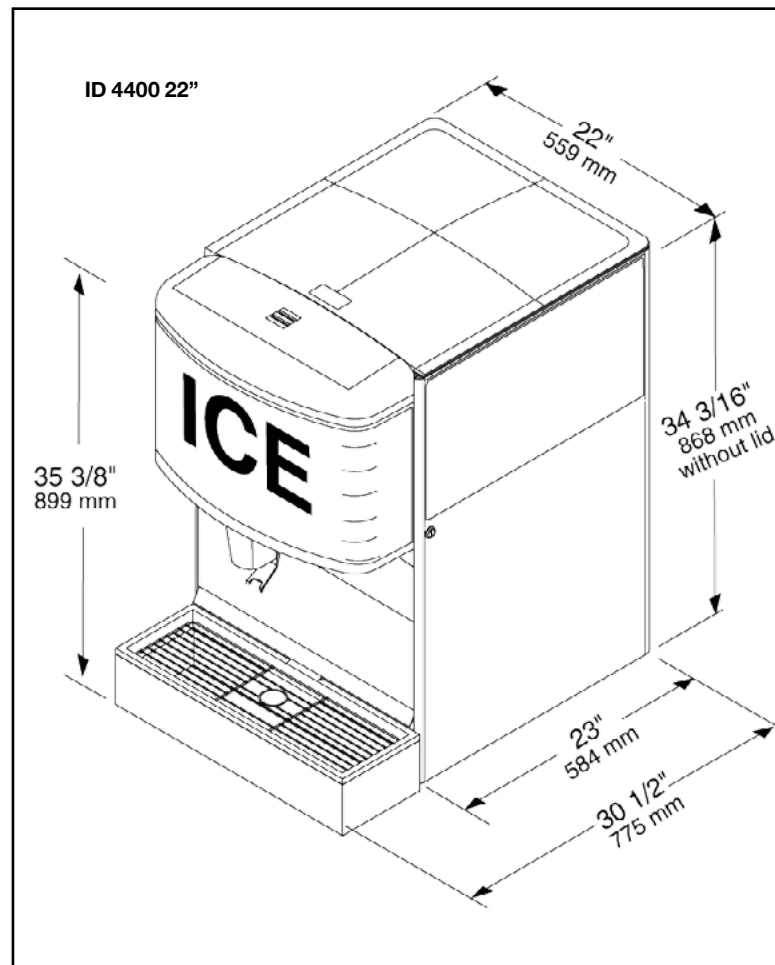

Distinctive Design

Fully insulated storage bin and drip tray controls condensation and helps avoid moisture related safety hazards.

- ID 4400 22" and 30" - Cube Ice
- ID 4400N - Nugget Ice

Dimensions

- ID 4400 22" - 35.375" H x 22" W x 30.5" D
(899 mm H x 559 mm W x 775 mm D)
- ID 4400 30" - 35.375" H x 30" W x 30.5" D
(899 mm H x 559 mm W x 762 mm D)
- ID 4400N 22" - 39.948" H x 22" W x 30.5" D
(1015 mm H x 559 mm W x 775 mm D)

Space Required

- ID 4400 22" - 22.5" W x 31" D
(572 mm W x 787 mm D)
- ID 4400 30" - 30.5" W x 31" D
(775 mm W x 787 mm D)
- ID 4400N 22" - 22.5" W x 31" D
(572 mm W x 787 mm D)

Weight

- ID 4400 22" - With Ice: 320 lbs (145 kg)
Shipping: 170 lbs (77 kg)
- ID 4400 30" - With Ice: 525 lbs (238 kg)
Shipping: 305 lbs (138 kg)
- ID 4400N 22" -With Ice: 340 lbs (154 kg)
Shipping: 185 lbs (84 kg)

Ice

- ID 4400 22" - Capacity: 180 lbs (82 kg)
- ID 4400 30" - Capacity: 250 lbs (133 kg)
- ID 4400N 22" - Capacity: 200 lbs (91 kg)

☐ Marine ICDI 2200 ☐ Marine ICDI 23300 ☐ Marine IC 415 ☐ Marine Turbo Carbonator



Lancer's **Marine** Products are designed using the highest quality materials and proven technology.



- **Marine ICDI 2200**
Ice Cooled Drop In Dispenser
- **Marine ICDI 23300**
Ice Cooled Drop In Dispenser
- **Marine IC 415**
Drop In Ice Chest
- **Marine Turbo Carbonator**

Accessories and Options

- Conversion Stand
- Marquee
- Merchandiser
- Splash Guards
- Power Supply

Certified by these agencies:



CUSTOMER SERVICE

Should you require more information about our products, please do not hesitate to contact our customer service team at custserv@lancerworldwide.com.



WARRANTY

For warranty specifics by product, contact your Lancer Sales Representative. Equipment design and/or specifications are subject to change without notice.

Marine Products

☐ Marine ICDI 2200 ☐ Marine ICDI 23300 ☐ Marine IC 415 ☐ Marine Turbo Carbonator

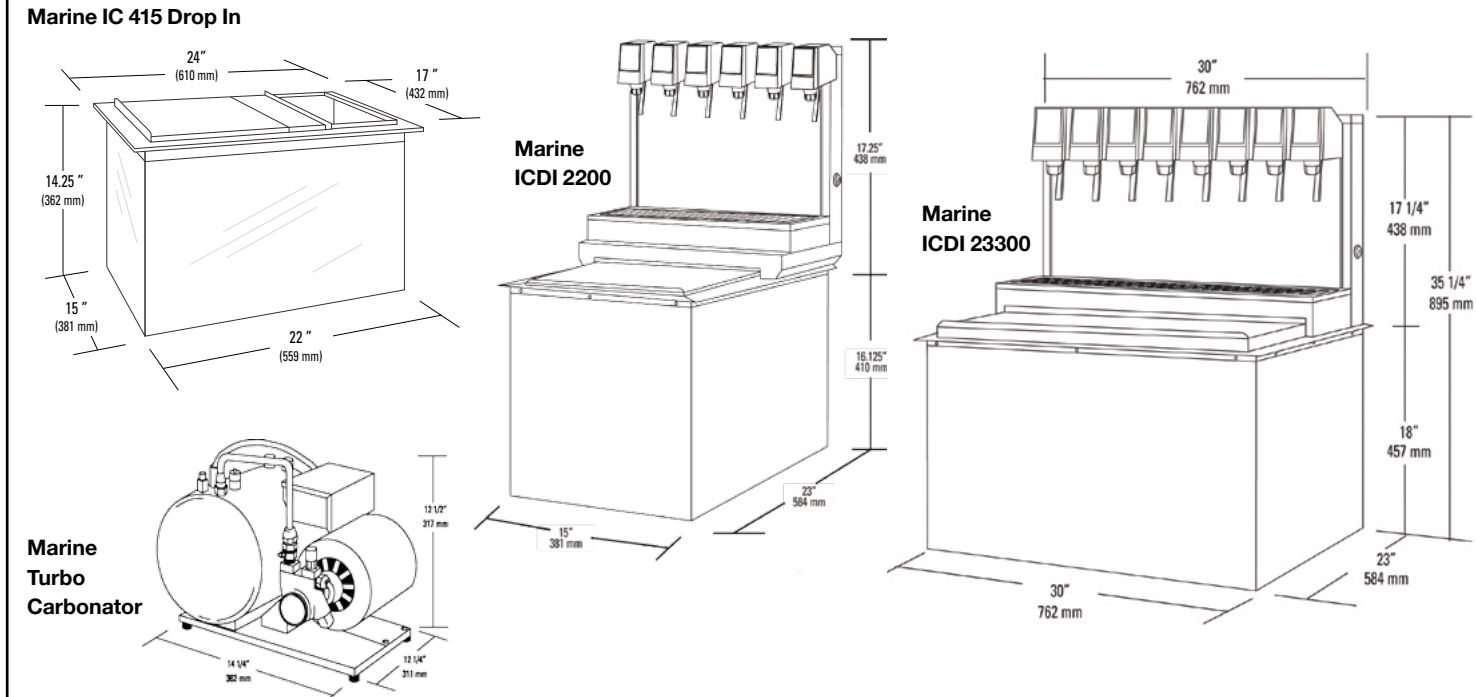

Dimensions

- IC 415 Drop In:
8 Circuit Cold Plate - 22" W x 15" D x 14.25" H
(559 mm W x 381 mm D x 362 mm H)
- ICDI 2200 - 33.375" H x 15" W x 23" D
(848 mm H x 381 mm W x 584 mm D)
- ICDI 23300 - 35.25" H x 30" W x 23" D
(895 mm H x 762 mm W x 584 mm D)
- Turbo Carbonator - Height: 12.5" H x 12.25" W x 14.25" D
(317 mm H x 311 mm W x 362 mm D)

Counter Cut-out for Drop In Units

- IC 415 Drop In - 1/4" (6.35 mm) larger than dimensions
- ICDI 2200 - 15.25" W x 23.25" D (387 mm W x 591 mm D)
- ICDI 23300 - 30.25" W x 23.25" D (768 mm W x 591 mm D)

Weight

- IC 415 Drop In: Shipping weight: 90 lbs (40.8 kg)
- ICDI 2200 - Operating: 166 lbs (75 kg) - Shipping: 175 lbs (79 kg)
- ICDI 23300 - Operating: 370 lbs (168 kg) - Shipping: 300 lbs (136 kg)
- Turbo Carbonator - Shipping: 35 lbs (15.87 kg)

Ice

- IC 415 Drop In - Capacity: 60 lbs (27.2 kg)
- ICDI 2200 - Capacity: 60 lbs (27.2 kg)
- ICDI 23300 - Capacity: 130 lbs (59 kg)

Electrical

- ICDI 2200 - 115V/60Hz
- ICDI 23300 - 24V/60Hz
- Turbo Carbonator - 115V/60Hz - 220V 50/60Hz available

Flex Manifold Configuration

- ICDI 2200 - 6 valves (3-2-1)
- ICDI 23300 - 8 valves (3-1-1-3)

Fittings

- ICDI 2200 - Syrup & soda inlets: 3/8" (9.5 mm) male barb
- ICDI 23300 - Syrup & soda inlets: 3/8" (9.5 mm) male barb
- Turbo Carbonator - CO2 Inlet: 1/4" male flare
- Water Inlet: 3/8" male flare
- Soda Outlet: 2 X 3/8" male flare

Pump

- Turbo Carbonator - 100 GPH (379 LPH)

Valves

- ICDI 2200 - LEV® and other valves available upon request
- ICDI 23300 - LEV® and other valves available upon request

Key Lock Switch

- ICDI 2200
- ICDI 23300

5.0 Series



With over five decades of proven beverage dispensing quality, Lancer Worldwide provides endless possibilities for beverage dispensing. **Soochee™** is designed for fresh, premium, handcrafted and better-for-you beverages. With a sleek modern design and a variety of visual display options, Soochee™ is the perfect way to influence consumer choices.

Industry leading tap and lever technology makes dispensing fresh beverages clean and easy. Quality craftsmanship, along with our best-in-class warranty options, Lancer Worldwide guarantees a hassle-free, highly profitable ownership experience.

Features

- No drip dispense
- Adjustable temperature control
- Symmetrical bowl cooling
- Tap and lever system
- R134a Refrigerant
- Pressure Low 104 psig / High 250 psig

Accessories and Options

Hot Swap Warranty Program
Available in 3.2, 5.3, 6.6, and 10.6, gallons

Certified by these agencies:



CUSTOMER SERVICE

Should you require more information about our products, please do not hesitate to contact our customer service team at custserv@lancerworldwide.com.



WARRANTY

For warranty specifics by product, contact your Lancer Sales Representative. Equipment design and/or specifications are subject to change without notice.

Soochee™ Refrigerated Beverage Dispensers

Series	Part Number	GTIN	Bowls	Bowl Capacity	Dispenser Dimensions WxDxH	Dispenser Weight	Electrical Frequency/Current Power/Compressor
--------	-------------	------	-------	---------------	----------------------------	------------------	---

3.0 Series

Soochee™ 3.1	85-11111A-GRY	00810050560009	1	3.2 gallons	7.87" x 17" x 28"	42 lbs	115V/60 Hz / 2.2 A 260 W / 1/6 HP
Soochee™ 3.2	85-11112A-GRY	00810050560016	2	3.2 gallons	15.75" x 17" x 28"	60 lbs	115V/60 Hz / 2.8 A 400 W / 1/6 HP
Soochee™ 3.3	85-11114A-GRY	00810050560030	3	3.2 gallons	23.62" x 17" x 28"	84 lbs	115V/60 Hz / 4.0 A 550 W / 1/3 HP
Soochee™ 3.4	85-11116A-GRY	00810050560054	4	3.2 gallons	31.5" x 17" x 28"	108 lbs	115V/60 Hz / 6.0 A 710 W / 1/3+ HP

3.0 Combo Series

Soochee™ 3.2C	85-11115A-GRY	00810050560047	2	1 x 3.2 gal 1 x 6.6 gal	23.62" x 17" x 28"	84 lbs	115V/60 Hz / 4.0 A 550 W / 1/3 HP
Soochee™ 3.3C	85-11117A-GRY	00810050560061	3	2 x 3.2 gal 1 x 6.6 gal	31.5" x 17" x 28"	108 lbs	115V/60 Hz / 6.0 A 710 W / 1/3+ HP

5.0 Series

Soochee™ 5.1	85-11121A-GRY	00810050560085	1	5.3 gallons	7.87" x 17" x 29.13"	44 lbs	115V/60 Hz / 2.2 A 260 W / 1/6 HP
Soochee™ 5.2	85-11122A-GRY	00810050560092	2	5.3 gallons	15.75" x 17" x 29.13"	68 lbs	115V/60 Hz / 3.4 A 550 W / 1/3 HP
Soochee™ 5.3	85-11124A-GRY	00810050560115	3	5.3 gallons	23.62" x 17" x 29.13"	90 lbs	115V/60 Hz / 7.0 A 730 W / 1/3+ HP
Soochee™ 5.4	85-11126A-GRY	00810050560139	4	5.3 gallons	31.5" x 17" x 29.13"	132 lbs	115V/60 Hz / 7.0 A 1100 W / 2 (1/3 HP)

5.0 Combo Series

Soochee™ 5.2C	85-11125A-GRY	00810050560122	2	1 x 5.3 gal 1 x 10.6 gal	23.62" x 17" x 29.13"	90 lbs	115V/60 Hz / 7.0 A 730 W / 1/3+ HP
Soochee™ 5.3C	85-11127A-GRY	00810050560146	3	2 x 5.3 gal 1 x 10.6 gal	31.5" x 17" x 29.13"	132 lbs	115V/60 Hz / 7.0 A 1100 W / 2 (1/3 HP)

6.0 Series

Soochee™ 6.1	85-11113A-GRY	00810050560023	1	6.6 gallons	15.75" x 17" x 24.4"	57 lbs	115V/60 Hz / 2.8 A 400 W / 1/6 HP
Soochee™ 6.2	85-11118A-GRY	00810050560078	2	6.6 gallons	31.5" x 17" x 24.4"	106 lbs	115V/60 Hz / 6.0 A 710 W / 1/3+ HP

X Series

Soochee™ X.1	85-11123A-GRY	00810050560108	1	10.6 gallons	15.75"x17"x 27.17"	66 lbs	115V/60 Hz / 3.4 A 550 W / 1/3 HP
Soochee™ X.2	85-11128A-GRY	00810050560153	2	10.6 gallons	31.5"x17"x 27.17"	126 lbs	115V/60 Hz / 7.0 A 1100 W / 2 (1/3 HP)

Soochee™ Refrigerated Beverage Dispensers

- 7" Single Valve □ 7" Two Valve □ 18" Five Valve □ 23" Six Valve



Lancer's **Tower 300 Series** are designed using the highest quality materials and proven technology providing our customers with consistent drink quality.

Features

- Stainless steel construction exterior and interior
- Available in multiple valve configurations
- Electrical for all units: 24V/60Hz
- LEV® valves standard, other valves available upon request
- Key lock switch
- Power supply included

Accessories and Options

- Merchandiser
- Lighted Marquee

Certified by these agencies:



CUSTOMER SERVICE

Should you require more information about our products, please do not hesitate to contact our customer service team at custserv@lancerworldwide.com.



WARRANTY

For warranty specifics by product, contact your Lancer Sales Representative. Equipment design and/or specifications are subject to change without notice.

Tower 300 Series Stainless Steel Dispensing Towers

- 7" Single Valve □ 7" Two Valve □ 18" Five Valve □ 23" Six Valve

Tower 300 Series Stainless Steel Dispensing Towers

7" Single Valve

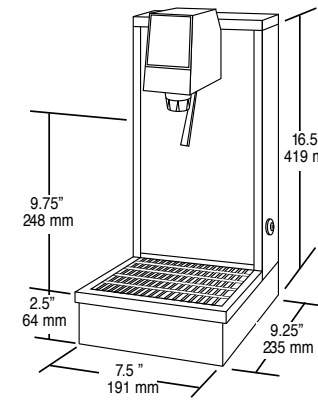

18" Five Valve

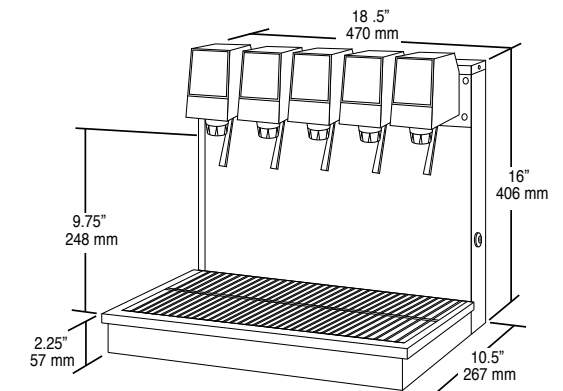

7" Two Valve

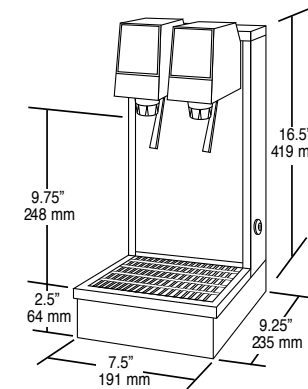

23" Six Valve

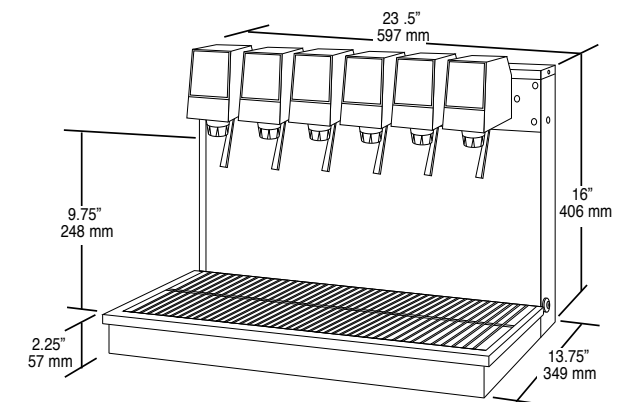

Dimensions

- 7" (1 or 2 valves) - 16.5" H x 7.5" W x 9.25" D including drip tray (419 mm H x 191 mm W x 235 mm D including drip tray)
- 18" (5 valves) - 16" H x 18.5" W x 10.5" D including drip tray (406 mm H x 470 mm W x 267 mm D including drip tray)
- 23" (6 valves) - 16" H x 23.5" W x 13.75" D including drip tray (406 mm H x 597 mm W x 349 mm D including drip tray)

Weight

- 7" (1 or 2 valves) - Shipping: 15 lbs (7 kg)
- 18" (5 valves) - Shipping: 37 lbs (17 kg)
- 23" (6 valves) - Shipping: 42 lbs (19 kg)

6 Brands



Touchscreen Tower (TST), the award-winning TST offers customers a personalized and unique dispensing experience. With just the touch of a button your customers can choose from a variety of beverage choices including trending specialty beverages like energy drinks and better for you drinks.

Features

- Lancer Link™ compatible
- Alternative beverage offerings
- Carbonated or non-carbonated
- Dispense up to 10 brands
- Large 10.4" interactive touchscreen
- Customizable user interface
- Customizable LED lighting patterns
- Small footprint
 - 9.4" (238.76 mm) x 18.7" (474.98 mm)
- Countertop installation
- Aether tea cartridge included

Accessories and Options

- Lancer Link™
- BIB Rack
- Chiller

Certified by these agencies:



CUSTOMER SERVICE

Should you require more information about our products, please do not hesitate to contact our customer service team at custserv@lancerworldwide.com.



WARRANTY

For warranty specifics by product, contact your Lancer Sales Representative. Equipment design and/or specifications are subject to change without notice.

Touchscreen Tower Beverage Dispensers

Touchscreen Tower Beverage Dispensers

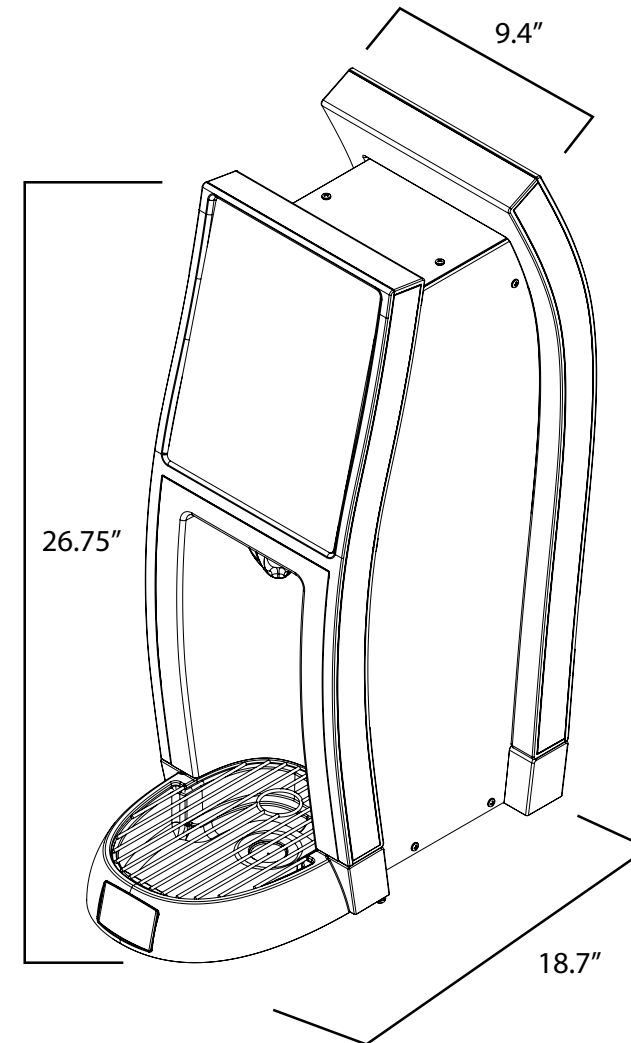

Available Configurations:

- 6 Brands - Up to 4 bonus flavors optional
- 8 Brands - Up to 2 bonus flavors optional
- 10 Brands - No bonus flavor options

Dimensions

Height: 26.75" (679.45 mm)
Width: 9.4" (238.76 mm)
Depth including drip tray: 18.7" (474.98 mm)

Weight

Shipping: 35lbs (15.88 kg)

Electrical

2 Amp, 24V, 50/60hz

Portion Control Push Button



The **Unicorn** is no longer a fantasy. Designed with a sleek retro look, the Unicorn font adds character and style to your bar or restaurant dining experience.

Features

- Promoting integrity and above counter brand advertising.
- The through bar mounting is sleek, self-contained with a small footprint.
- Products are served with pinpoint accuracy, by pulling the handle, holding the flavor button, or by the optional portion control buttons.
- Lancer Flow Control Valve (LFCV) Technology
- 4 Brands and carbonated water
- Available for Single brand

Accessories and Options

- Power Supply
- Chiller
- Branding Medallion

Certified by these agencies:



CUSTOMER SERVICE

Should you require more information about our products, please do not hesitate to contact our customer service team at custserv@lancerworldwide.com.



WARRANTY

For warranty specifics by product, contact your Lancer Sales Representative. Equipment design and/or specifications are subject to change without notice.

Unicorn Tower Beverage Dispenser

Portion Control Push Button

Unicorn Tower Beverage Dispenser

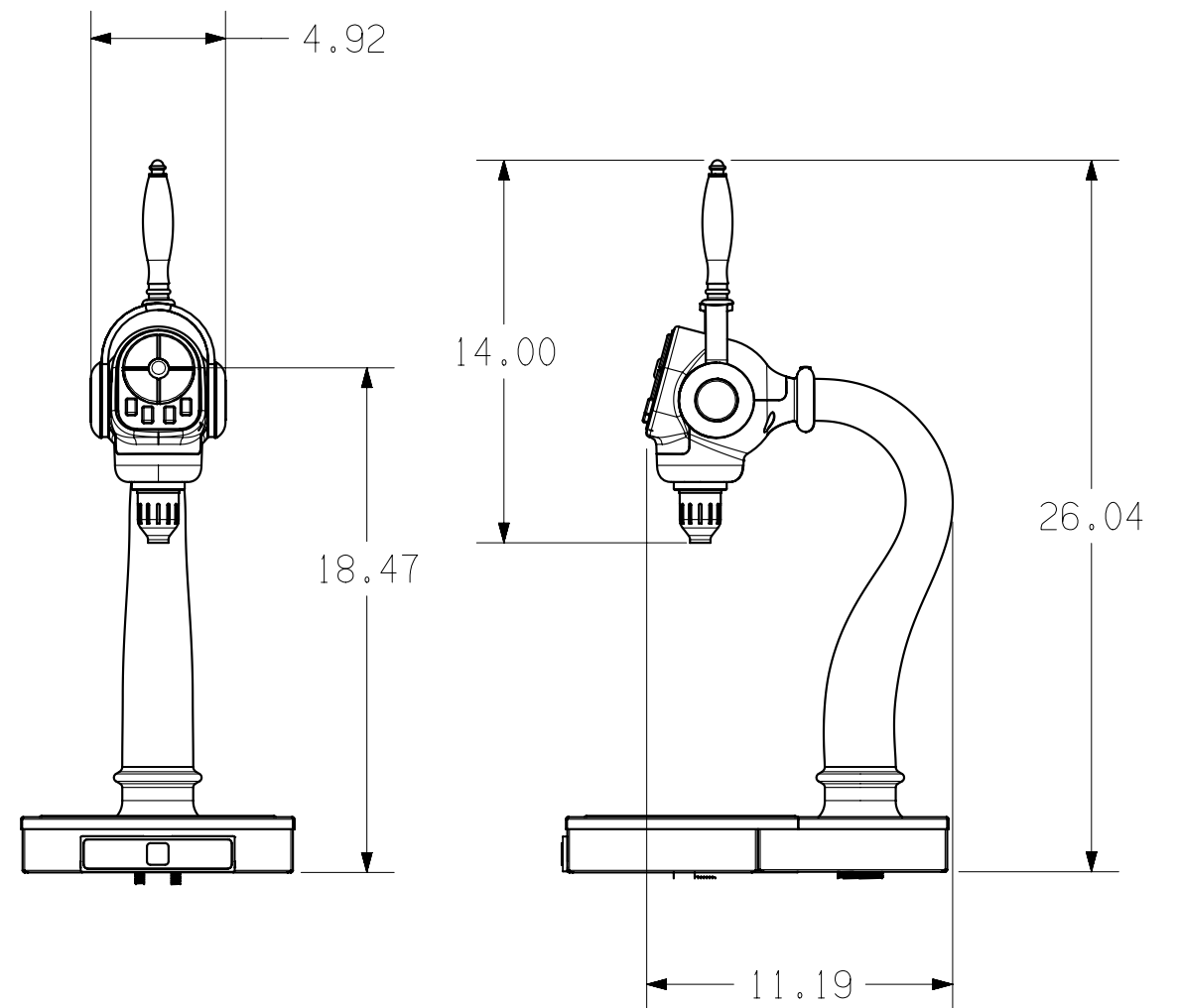

Dimensions

Tower
Width: 9.12" (232 mm)
Depth: 14.00" (356 mm)
Height: 27.50" (699 mm)

Control Box (Valves)

Width: 13.075" (323 mm)
Depth: 8.12" (206 mm)
Height: 6.07" (154 mm)

Electrical

24V/50/60Hz
(transformer not included)

Weight

Shipping: 35 lbs (16 kg)

Fittings

Carbonated water inlet: 3/8" quick disconnect
Syrup inlets: 1/4" male barb

Flow Rate

LFCV: 1.75 oz/sec

- LEV® CS (3.0) LEV® EF (3.0) LEV® PB (3.0) LEV® PC (3.0) LEV® SSL (3.0)
- LEV® CS (4.5) LEV® EF (4.5) LEV® PB (4.5) LEV® PC (4.5) LEV® SSL (4.5)



LEV® 3.0 SSL
with optional
water button

The **Lancer Electric Valve (LEV®)** is the best in class and best selling valve on the market. It is built with the highest quality materials and proven technology to provide our customers with consistent drink quality and reliability.

Features

- Available in 3 and 4.5 oz/second flow rates
- Lowest “Life Cost” of operation available
- Simple design gives high reliability
- Widest range of ratio control (2:1 - 10:1)
- Tamper-proof ratio setting

Accessories and Options

- Nozzle
- Syrup Separator Nozzle
- Front Water Button
- Diffuser
- Bare Valve

Certified by these agencies:

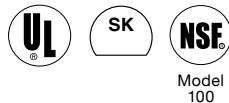

WARRANTY

For warranty specifics by product, contact your Lancer Sales Representative. Equipment design and/or specifications are subject to change without notice.

CUSTOMER SERVICE

Should you require more information about our products, please do not hesitate to contact our customer service team at custserv@lancerworldwide.com.

Lancer Electric Valves (LEV®)

- LEV® CS (3.0) LEV® EF (3.0) LEV® PB (3.0) LEV® PC (3.0) LEV® SSL (3.0)
- LEV® CS (4.5) LEV® EF (4.5) LEV® PB (4.5) LEV® PC (4.5) LEV® SSL (4.5)

Lancer Electric Valves (LEV®)

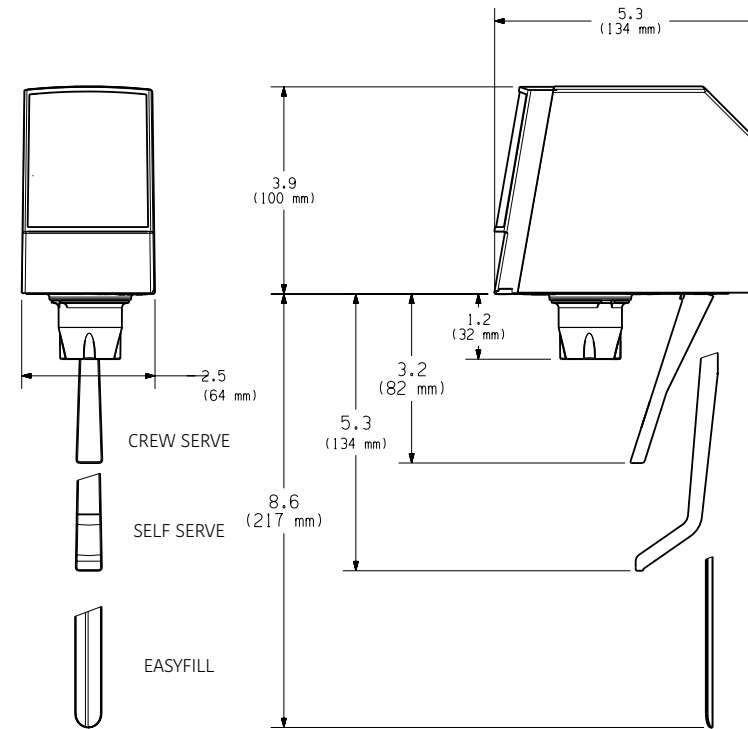

Distinctive Design

Available in two nozzle sizes with the following drink flow rates:

LEV 3.0: 1.5 oz/s - 3.0 oz/s
(44.4 ml/s – 88.8 ml/s)

LEV 4.5: 2.5 oz/s - 4.5 oz/s
(73.9 ml/s – 133.1 ml/s)

Available Configurations:

- Push Button (PB)
- Portion Control (PC)
- Crew Serve (CS)
- Self-Serve Lever (SSL)
- Easyfill (EF)

Flowing Pressure

Water: 40 - 110 psig (2.8 - 7.7 bar)
Syrup (Sugar): 20 - 70 psig (1.4 - 4.9 bar)
Syrup (Diet/Light): 10 - 70 psig (0.7 - 4.9 bar)

Ratio Adjustment Range

2.0 - 10.0 Water/Syrup by Volume
(dependent on finished drink flow rate)

Electrical

24V, 50/60 Hz

Mounting

Uses LEV® Mounting Block
LEV® mounting block has the same mounting screw hole pattern as the following:

- Dole SEV
- Dole FFV
- Cornelius UF1, SF1
- McCann Turbo Flo Jr.



**Mechanical Version
Coming Soon**



VersaPour
Self-Serve Lever (SSL)

The **VersaPour** valve is built with the highest quality materials and proven technology to provide our customers with consistent drink quality and reliability.

Features

- Lowest “Life Cost” of operation available
- Simple design gives high reliability
- 3 oz/second flow rates
- Widest range of ratio control (3.0-9.0)

Accessories and Options

- Nozzle
- Syrup Separator Nozzle
- Front Water Button
- Diffuser
- Bare Valve

Certified by these agencies:

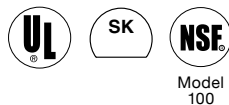

CUSTOMER SERVICE

Should you require more information about our products, please do not hesitate to contact our customer service team at custserv@lancerworldwide.com.



WARRANTY

For warranty specifics by product, contact your Lancer Sales Representative. Equipment design and/or specifications are subject to change without notice.

VersaPour Electric Valves

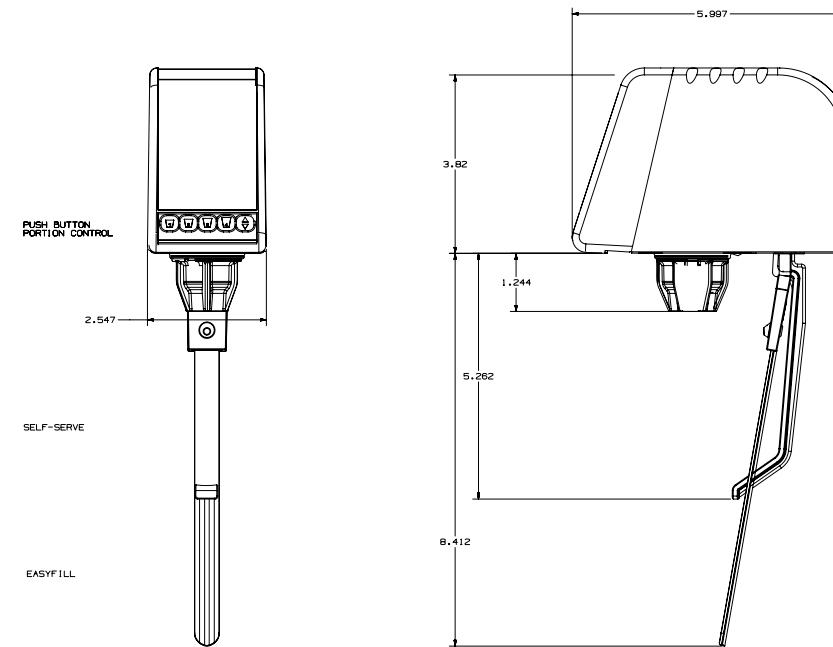

Distinctive Design

Drink flow rates:

LEV 3.0: 1.5 oz/s - 3.0 oz/s
(44.4 ml/s – 88.8 ml/s)

Available Configurations:

- Push Button (PB)
- Portion Control (PC)
- Self-Serve Lever (SSL)
- Easyfill (EF)

Flowing Pressure

Water: 40 - 110 psig (2.8 - 7.7 bar)
Syrup (Sugar): 20 - 70 psig (1.4 - 4.9 bar)
Syrup (Diet/Light): 10 - 70 psig (0.7 - 4.9 bar)

Ratio Adjustment Range

3.0-9.0 Water/Syrup by Volume
(dependent on finished drink flow rate)

Electrical

24V, 50/60 Hz

Mounting

VersaPour mounting block has the same mounting screw hole pattern as the following:

- Dole SEV
- Dole FFV
- Cornelius UF1, SF1
- McCann Turbo Flo Jr.



Volumetric Valve
3.0 SSL



LVV Bluetooth Key

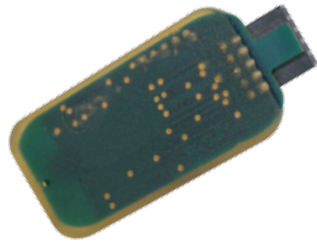

Accessories and Options

Hand-held Programmer (PN: 52-1420/03-SP)

Syrup Separator Nozzle (PN: 54-0201-SP)

Front Water Button

Soda Button

Basic Valve (No Cover & ID Panel)

Certified by these agencies:



CUSTOMER SERVICE

Should you require more information about our products, please do not hesitate to contact our customer service team at custserv@lancerworldwide.com.

The **Volumetric Valves** are built with the highest quality materials and proven technology to provide our customers with consistent drink quality and reliability.

Features

- Consistent “Best in Class” performance
- Volumetric metering give accurate ratio over life of valve
- Once set, no adjustment
- Over 500,000 Lancer Volumetric Valves in the market

Get more performance from your valves with **Lancer’s Field Programming Tool!**

- Download the Apple or Android™ App
- Use your mobile device supporting Bluetooth®
- Set ratio in half the time
- Capabilities include:
 - Calibrate Ratio - Set Ratio
 - Set Portion Sizes - Set Carb/Non-Carb
 - Store Settings - Timed Pours
 - Copy Settings - Syrup Purge
- LVV Bluetooth Key (PN: 64-5111-SP)
Available from your Lancer Sales Office



WARRANTY

For warranty specifics by product, contact your Lancer Sales Representative. Equipment design and/or specifications are subject to change without notice.

Volumetric Metering Valves

Volumetric Metering Valves

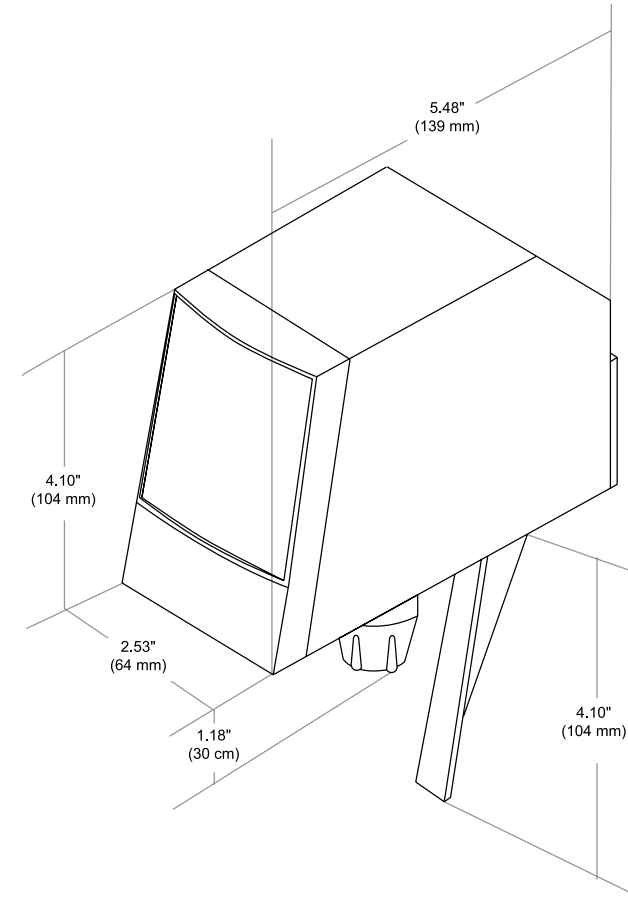

Distinctive Design

Available in the following nozzle sizes and drink flow rates:

- Push Button (PB)
- Portion Control (PC)
- Crew Serve (CS)
- Self-Serve Lever (SSL)

3.0 oz/s (90 ml/s)
(Grey flow washer assembly)

2.3 oz/s (68 ml/s)
(White flow washer assembly)

1.5 oz/s (45 ml/s)
(Red flow washer assembly)

Lower flow rates are typically used to reduce foaming due to the product and/or altitude.

Examples: At high altitudes, 1.5 oz/s is often used to reduce foaming that occurs. Root Beer is a foamy product that is often dispensed at 1.5 oz/s. Some products do not contain anti-foaming ingredients and 2.3 oz/s is often used.

Flowing Pressure

- Water: 40 - 110 psig (2.8 - 7.7 bar)
- Syrup (Sugar): 20 - 70 psig (1.4 - 4.9 bar)
- Syrup (Diet/Light): 10 - 70 psig (0.7 - 4.9 bar)

Electrical

24V, 50/60 Hz

Mounting

- Uses LEV® Mounting Block
- LEV® mounting block has the same mounting screw hole pattern as the following:
 - Dole SEV
 - Dole FFV
 - Cornelius UF1, SF1
 - McCann Turbo Flo Jr.



Lancer's **Bag-In-Box (BIB) Racks** are designed using the highest quality materials and proven technology.

Features

- Space saving
- BIB racks can be built up to 30 pumps
- Pump Mounting is Top, Right, Left, or Center Top Mount.
- Easy BIB syrup change out
- Customized systems pre-assembled to your company's specifications in multiple configurations.

Accessories and Options

- Powder coated black finish
- Flat or inclined shelves
- Single, double, or triple wide shelves
- Top shelves
- Pump mounts available top, right or left side
- Castors
- Flojet or Shurflo BIB pumps
- Flojet or Shurflo transfer valves
- Lancer and/or Liqui Box connectors
- Regulator management systems

Certified by these agencies:



CUSTOMER SERVICE

Should you require more information about our products, please do not hesitate to contact our customer service team at custserv@lancerworldwide.com.



WARRANTY

For warranty specifics by product, contact your Lancer Sales Representative. Equipment design and/or specifications are subject to change without notice.

BIB Racks Organizational System

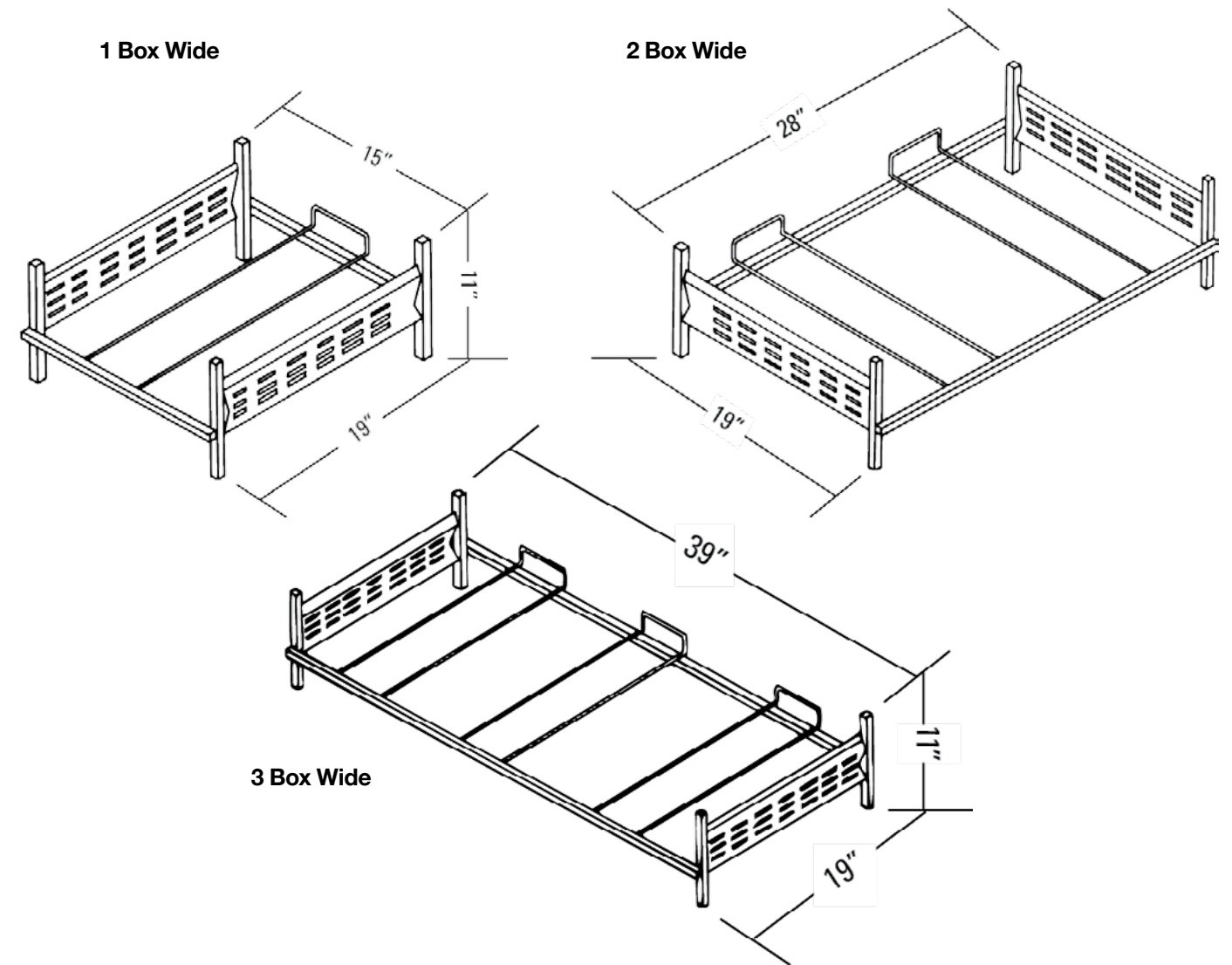

Dimensions

1 Box Wide

- Modular Flat Shelf
11" H x 15" W x 19" D (279.4 mm H x 381 mm W x 482.6 mm D)
- Modular Incline Shelf
12" H x 15" W x 19" D (304.8 mm H x 381 mm W x 482.6 mm D)

2 Box Wide

- Modular Flat Shelf
11" H x 28" W x 19" D (279.4 mm H x 711.2 mm W x 482.6 mm D)
- Modular Incline Shelf
12" H x 27" W x 19" D (304.8 mm H x 685.5 mm W x 482.6 mm D)

3 Box Wide

- Modular Flat Shelf
11" H x 39" W x 19" D (279.4 mm H x 990.6 mm W x 482.6 mm D)
- Modular Incline Shelf
12" H x 39" W x 19" D (304.8 mm H x 990.6 mm W x 482.6 mm D)

□ 15" x 23" □ 23" x 23" □ 30" x 23"



15" x 23"



23" x 23"



30" x 23"

Lancer's **Conversion Stands** are constructed with robust stainless steel. Enjoy higher quality at a better price.



WARRANTY
For warranty specifics by product, contact your Lancer Sales Representative. Equipment design and/or specifications are subject to change without notice.

CUSTOMER SERVICE
Should you require more information about our products, please do not hesitate to contact our customer service team at custserv@lancerworldwide.com.

Conversion Stands

□ 15" x 23" □ 23" x 23" □ 30" x 23"

Conversion Stands

15" x 23"

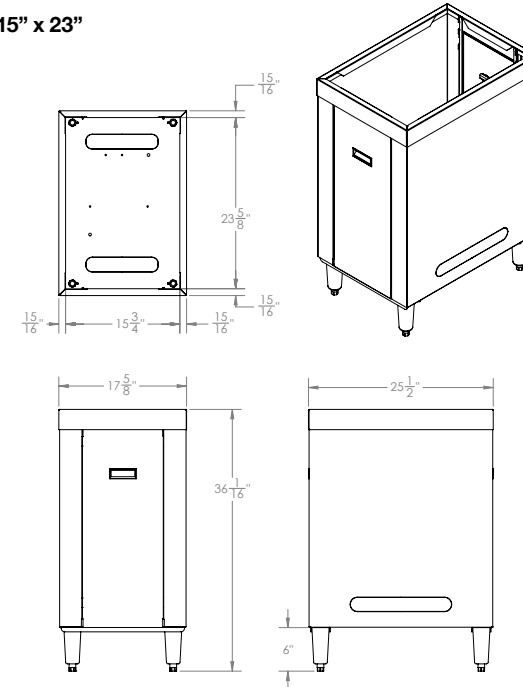

23" x 23"

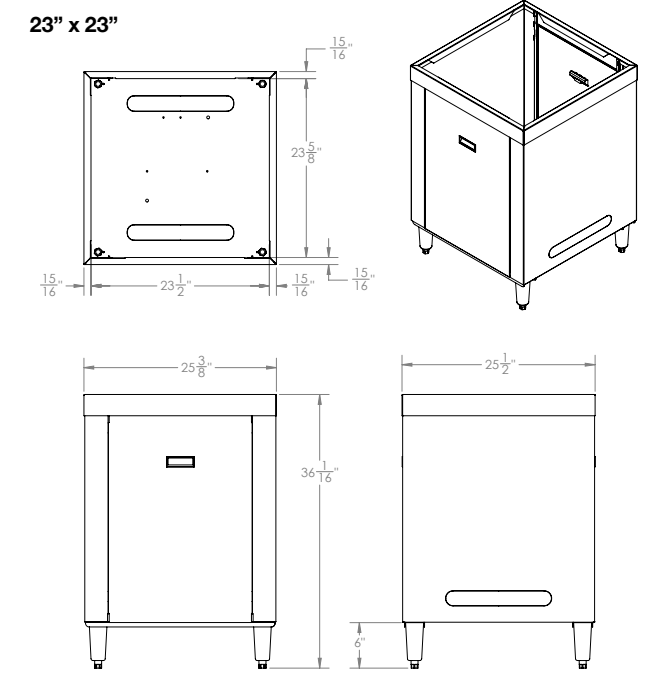

30" x 23"

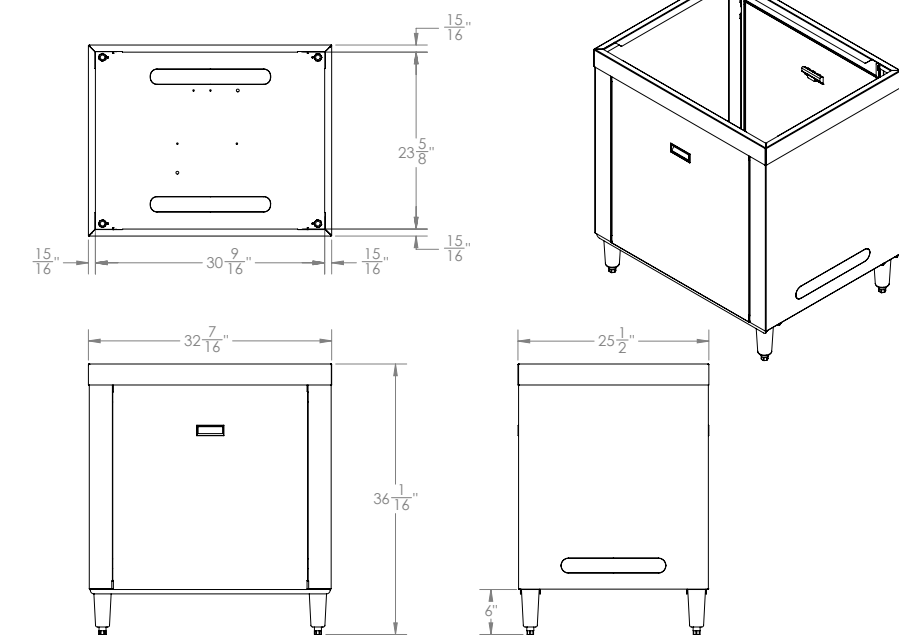

Dimensions

- 15" (381 mm) x 23" (584.2 mm)
- 23" (584.2 mm) x 23" (584.2 mm)
- 30" (762 mm) x 23" (584.2 mm)

Weight

- 15x23 - 46 lbs (20.86 kg); Shipping weight: 70 lbs (31.75 kg)
- 23x23 - 54 lbs (24.49 kg); Shipping weight: 70 lbs (31.75 kg)
- 30x23 - 62 lbs (28.12 kg); Shipping weight: 70 lbs (31.75 kg)

Delta 9100 Remote 2500 Remote (9cir)

Delta 9100



2500 Remote



The **Delta 9100 and 2500 Remote** CED Remote Recirculation systems are a benchmark in the fountain dispensing market. Built to the quality standards that Lancer is known for, these units utilize cold carbonation and a stainless steel recirculating pump to provide optimum temperature product to a remote tower location

Features

- Built in Cold Carbonation
- Stainless Steel Construction exterior and interior
- CFC Free Refrigerant
- Lancer Electronic Ice Bank Control and Liquid Level Control

Certified by these agencies:



CUSTOMER SERVICE

Should you require more information about our products, please do not hesitate to contact our customer service team at custserv@lancerworldwide.com.



WARRANTY

For warranty specifics by product, contact your Lancer Sales Representative. Equipment design and/or specifications are subject to change without notice.

Delta 9100 / 2500 Remote Recirculation Systems

Delta 9100 Remote 2500 Remote (9cir)

Distinctive Design

- **Delta 9100** - Six chilled syrup circuits and provision for chilled plain water.
- **2500 Remote** - 9 circuits

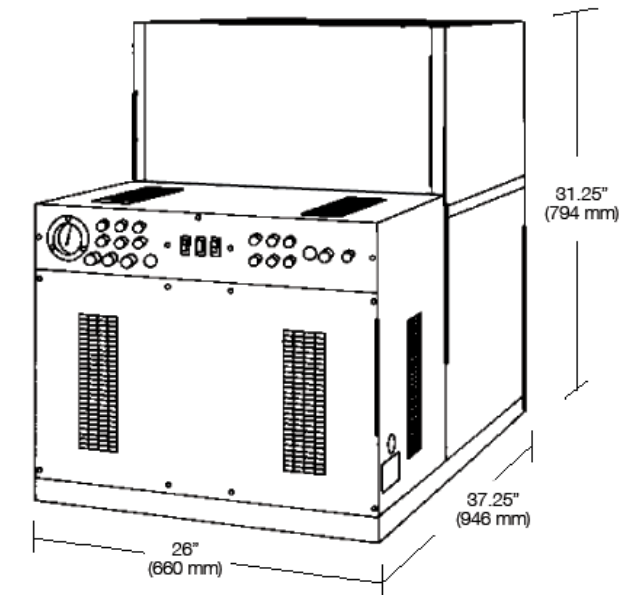
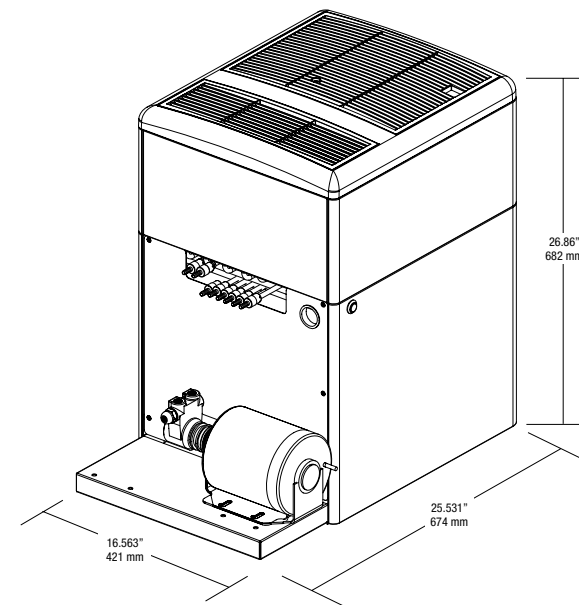

Dimensions

Delta 9100 - 26.86" H x 16.563" W x 25.531" D
(682 mm H x 421 mm W x 674 mm D)
2500 Remote - 31.25" H x 26" W x 37.25" D
(794 mm H x 660 mm W x 946 mm D)

Weight

Delta 9100 - With water: 220 lbs (99 kg) - Shipping: 170 lbs (77 kg)
2500 Remote - With water: 529 lbs (240 kg) - Shipping: 360 lbs (163 kg)

Electrical

Delta 9100 - 115V/60Hz - 230V/50Hz
2500 Remote - 115V/60Hz, 16 Amps - 230V/50Hz, 9 Amps

Compressor

Delta 9100 - 1/3 hp
2500 Remote - 3/4 hp

Fittings for 2500 Remote

Stainless steel 3/8" Flare
Inlet and Outlet; water, soda, syrup; 1/4" Flare, CO2 Inlet

Water Requirements for both units

Minimum flowing pressure of 25 PSIG
(1.76 kg/cm², 1.72 BAR)
Maximum static pressure of 50 PSIG
(3.52 kg/cm², 3.45 BAR)

Ice Bank Weight for Delta 9100

22-24 lbs (10kg - 11.8kg)

Carbon Dioxide (CO2)

Delta 9100 - Minimum pressure of 70 PSIG
(4.92 kg/cm², 4.83 BAR)
Maximum pressure of 80 PSIG
(5.62 kg/cm², 5.52 BAR)

2500 Remote - Minimum pressure of 100 PSIG
Maximum pressure of 120 PSIG

WARNING

If water source exceeds 50 PSIG (3.52 KG/CM²), a recommended water regulator assembly (PN 18-0253) must be used to limit water pressure to 50 PSIG (3.52 KG/CM²). Failure to use regulator will result in improper performance of dispenser.



Lancer's **Turbo Carbonator** is designed using the highest quality materials and proven technology.

Features

- Superior quality and reliability
- Built-in, advanced diagnostics system
- Anderson Brass vented check valve
- Heavy duty, high capacity tank
- Solid state electronics
- High capacity for fast flow valves
- ASSE approved check valve
- Stainless steel backflow preventor

Performance Data

- With 60°F inlet water, **Turbo Carbonator** will provide inline carbonation levels of 6.0 volumes
- With 75°F inlet water, **Turbo Carbonator** will provide carbonation levels of 5.5 volumes
- Maximum flow with 75°F inlet water **Turbo Carbonator** will provide carbonation levels of 5.3 volumes

Certified by these agencies:



CUSTOMER SERVICE

Should you require more information about our products, please do not hesitate to contact our customer service team at custserv@lancerworldwide.com.



WARRANTY

For warranty specifics by product, contact your Lancer Sales Representative. Equipment design and/or specifications are subject to change without notice.

Turbo Carbonator

Turbo Carbonator

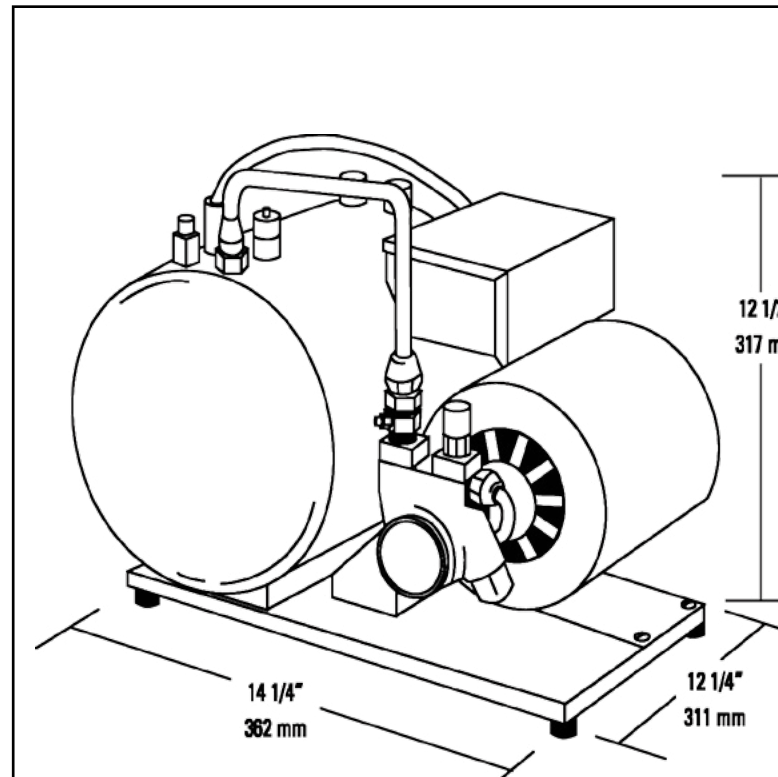

MODELS

Domestic

- 115V Turbo w/ standard brass VCV
- 115V Turbo w/ standard brass VCV & Insulated
- 115V Turbo w/ "T" & standard brass VCV

Export

- 220V Turbo w/ standard brass VCV
- 220V Turbo w/ standard brass VCV & Insulated
- 220V Turbo w/SS VCV

(All models include built-in diagnostics and vented check valve.)

Dimensions

12.5" H x 12.25"W x 14.25 D
(317mm H x 311mm W x 362mm D)

Weight

Shipping: 35 lbs (15.87 kg)

Electrical

115V/60Hz
230V/50/60Hz available

Tank Operating

Capacity: 215 oz (6.4 L)

Fittings

CO2 Inlet: 1/4" male flare
Water Inlet: 3/8" male flare
Soda Outlet: 2 X 3/8" male flare

Pump

100 GPH (379 LPH)

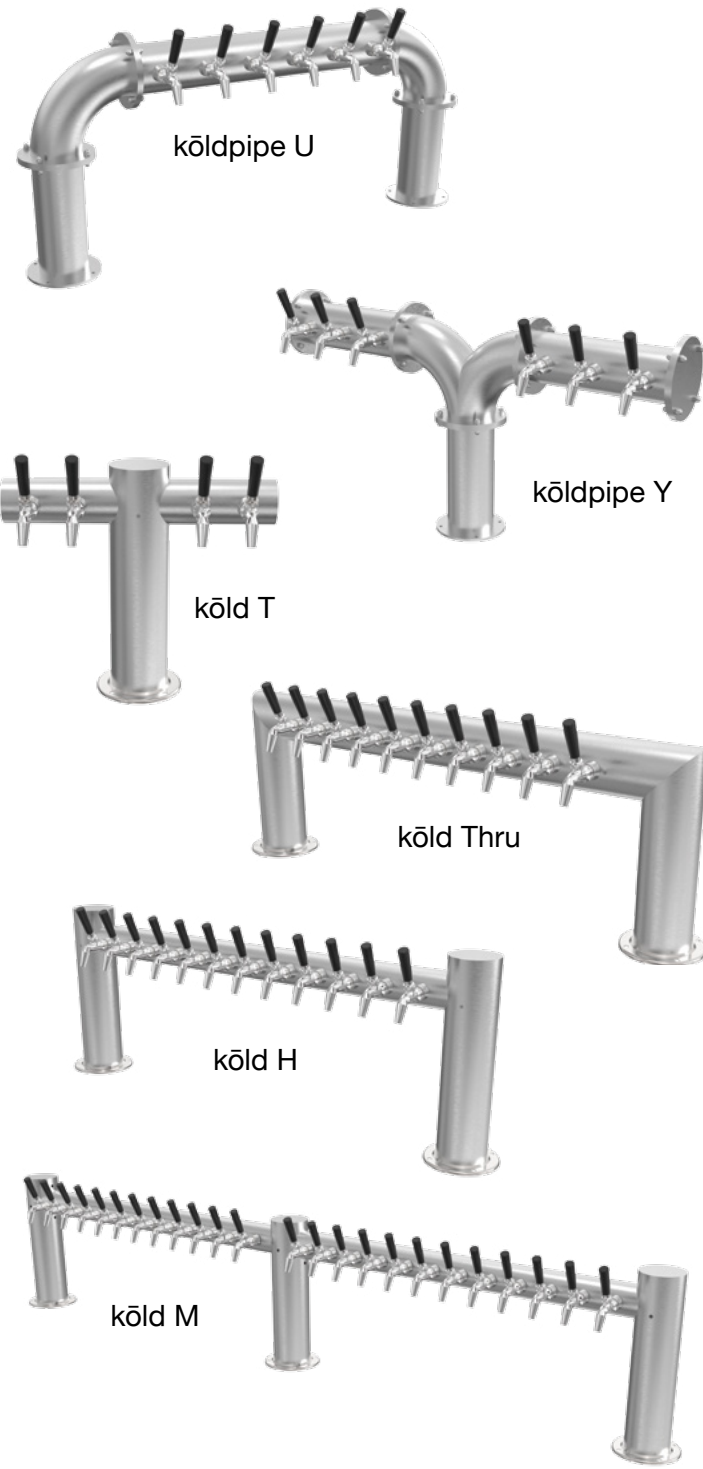

With more than 50 years experience, Lancer Worldwide has a team of experts ready to provide you with a draft system that is unique to your business. With the innovative patent pending **köld-Draw™ Technology** our **Towers** provide a customizable and profitable solution to pouring any beverage at any time in the most energy efficient package the industry can offer.

All **Towers** feature the following:

- Patent Pending **köld-Draw™ Technology**
- Brushed 304 Stainless Steel Finish
- Modular Spout 304 Stainless Steel Faucets Included
- Product Connection - 1/4" OD 304 Stainless Steel Tubes with 1/4" Barb
- Glycol Connection - 3/8" ID x 1/2" OD Polyethylene Tubing



WARRANTY

For warranty specifics by product, contact your Lancer Sales Representative. Equipment design and/or specifications are subject to change without notice.

CUSTOMER SERVICE

Should you require more information about our products, please do not hesitate to contact our customer service team at custserv@lancerworldwide.com.

Faucet Towers

Faucet Towers

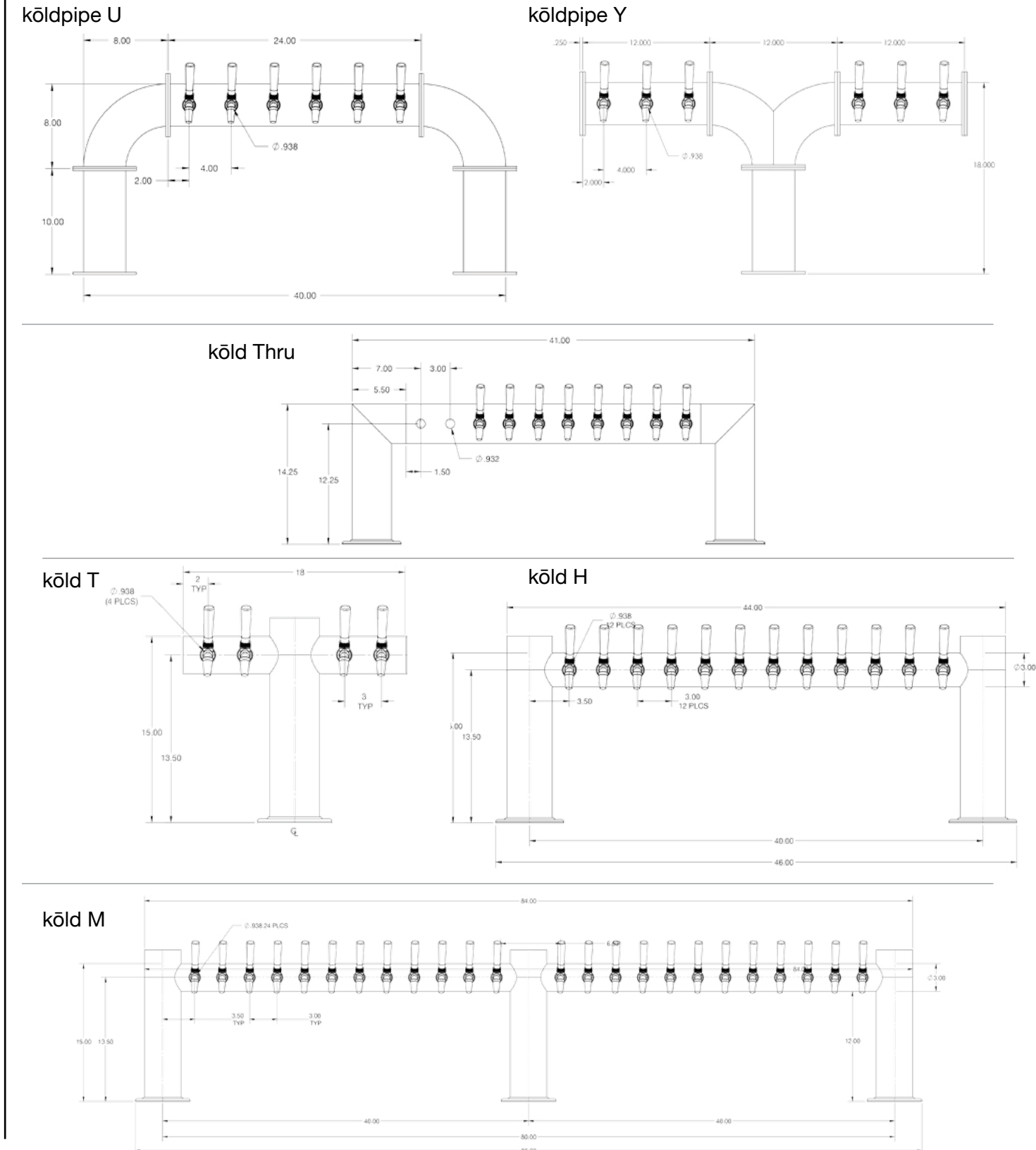



The **köld Tap** forward sealing design shuts off the flow at the front of the tap which in turn keeps wild yeast and bacteria out of the interior of the tap body.

köld Tap uses a sliding shuttle that holds the o-ring perfectly in position allowing a more reliable connection to be made with the seal. This is what makes **köld Tap** the most reliable forward sealing design available.

köld Tap body and internal components are made from 304 grade stainless steel. **köld Tap** uses a threaded spout that can easily be removed and replaced with the following spouts to suit your beer style:

- Stout Spout
- Growler Filler Spout

Eliminate the need to ever replace your beer taps again and simply just purchase the spouts that you need.

PATENTED DESIGN

Taps are designed and sold under several registered Patents with USPTO (US6457614, US6626420, US7077299) and WIPO.



WARRANTY

For warranty specifics by product, contact your Lancer Sales Representative. Equipment design and/or specifications are subject to change without notice.

Stout Spout



Growler Filler Spout



köld Tap Faucets

köld Tap Faucets

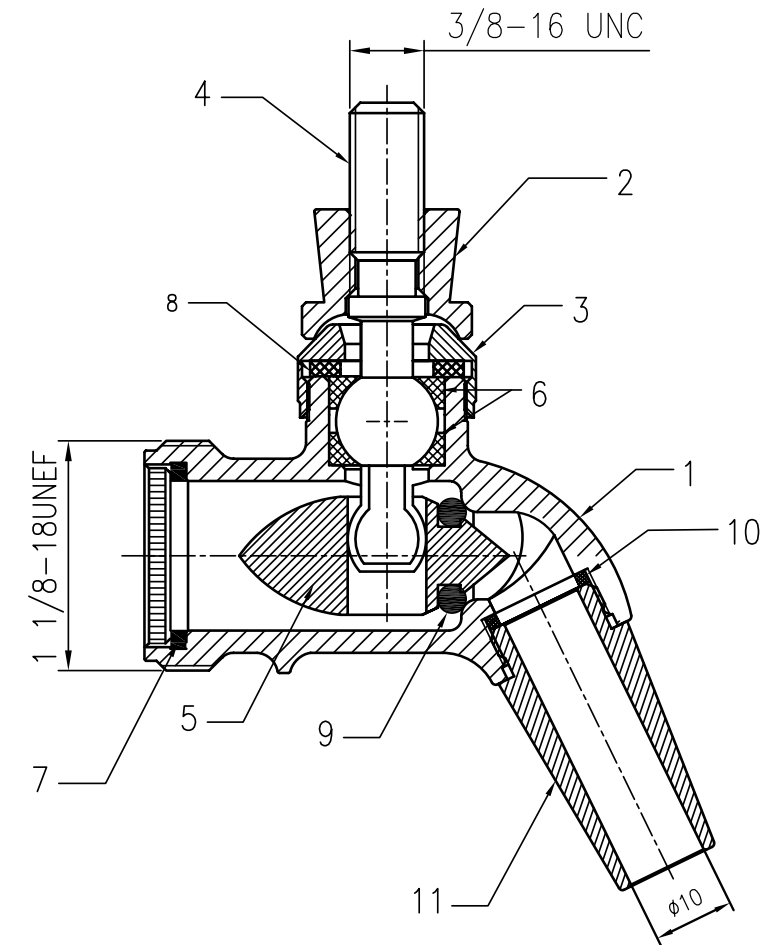

1. Tap Body
2. Tap Handle Collar
3. Tap Bonnet
4. Tap Lever
5. Tap Shuttle
6. Ball Seals
7. Tap Coupling Washer
8. Bonnet Washer

9. Shuttle Seat O-Ring
 10. Nozzle Washer
 11. 10mm Standard Nozzle
- REPLACEMENT SEAL KIT
PART: #8480
(To suit tap models 8022 & 8039)
INCLUDES ABOVE PARTS:
6, 7, 8, 9, 10



köld Chill glycol chillers are engineered for performance and value.

Features

- Digital temperature control for maximum efficiency
- Quick mount system: save time and money, and avoid frustration with easy installation
- Multiple mounting positions
- Insulated reservoir and lines protects glycol temperature and minimizes condensation
- Anti-vibration pads reduce motor noise
- Air-cooled condenser
- Poly tank reservoir
- Brazed plate heat exchanger
- Rugged powder-coated steel cabinet



WARRANTY

For warranty specifics by product, contact your Lancer Sales Representative. Equipment design and/or specifications are subject to change without notice.

CUSTOMER SERVICE

Should you require more information about our products, please do not hesitate to contact our customer service team at custserv@lancerworldwide.com.

köld Chill Glycol Chillers

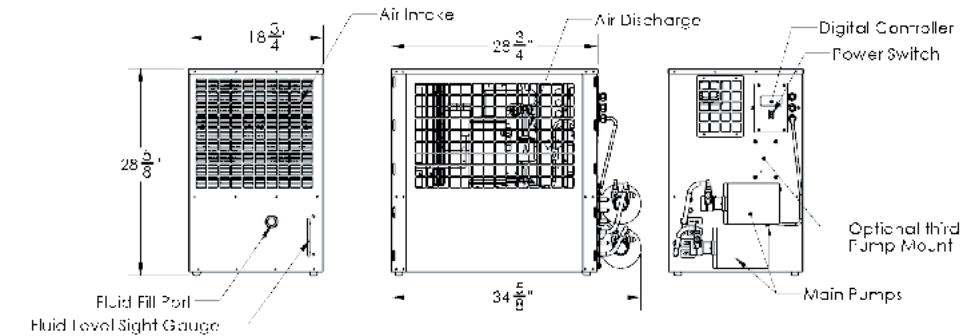
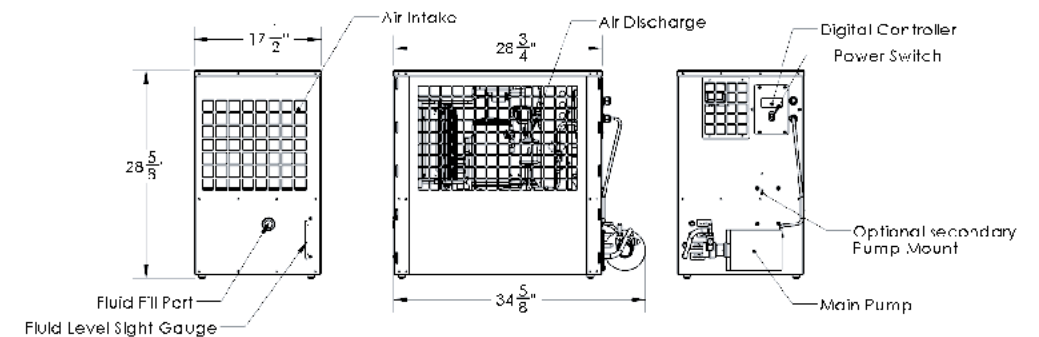
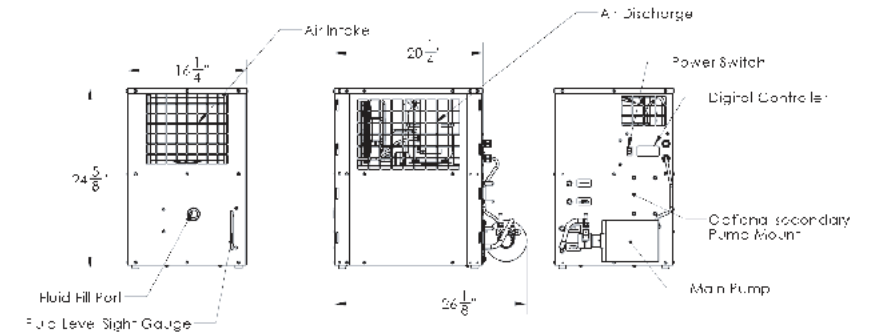

Dimensions L x W x H (Including Pumps and Motors)	26-1/8" x 16-1/4" x 24-5/8"	34-5/8" x 17-1/2" x 28-5/8"	34-5/8" x 18-3/4" x 28-5/8"	
Electrical	Voltage	120VAC, 60Hz, 1P	208-240VAC, 60Hz, 1P	208-240VAC, 60Hz, 1P
	RLA (Rated Load Amps)	16	16	25
	MCA (Min. Circuit Ampacity)	18.6	19.4	29.2
	MOCP (Max. over Current Protection)	28.6	32.0	47.2
	Plug Type	5-20P	6-20P	L6-30P
Refrigeration Circuit	Compressor	1/2 hp	1 hp	1-1/2 hp
	Cooling Capacity	3,600 BTU/hr	7,250 BTU/hr	11,500 BTU/hr
	Refrigerant	R134a		
Fluid Circuit	Reservoir Capacity	4 Gallon		
	Glycol Pumps	Single Pump (dual pump capable)		Dual Pump (Triple pump capable)
	Fluid Connections	3/8" Barbed		
	Pump	80 GPH 1/3 HP Rotary Vane		



köld Seal noncabled and cabled insulated bundles are comprised of flushable **köld Seal** tubes, each color coded and individually numbered, and red/blue-colored coolant tubes strategically placed and designed to provide optimum cooling and flavor protection.

A tear-resistant aluminized film wrap over the group of tubes further enhances the insulating properties of the 3/4" thick tubular foam sleeve. The black extruded jacket with slip agent minimizes friction is branded with product identification, NSF listingmarks, and footage counter marks.

- Used for draft beer, wine, cocktails, coffee and other non-alcoholic beverages
- Gas barrier layer with outstanding hygienic quality
- Ultra smooth lining
- No cross contamination of flavors
- Cut to length upon order, up to 500 feet
- Color coded lines for easy identification

Certified by these agencies:



CUSTOMER SERVICE

Should you require more information about our products, please do not hesitate to contact our customer service team at custserv@lancerworldwide.com.



WARRANTY

For warranty specifics by product, contact your Lancer Sales Representative. Equipment design and/or specifications are subject to change without notice.

köld Seal Insulated Barrier Tubing Bundles



Part #	Description	Max Bundle OD	Min Bend Radius	Clamp Size	List Price
585-TL-432	4 3/8" Product + 2 Glycol	3.0"	12"	14.0 mm	\$20
585-TL-632	6 3/8" Product + 2 Glycol	3.4"	14"	14.0 mm	\$22
585-TL-832	8 3/8" Product + 2 Glycol	3.5"	8"	14.0 mm	\$26
585-TL-1034	10 3/8" Product + 4 Glycol	3.8"	12"	14.0 mm	\$30
585-TL-1234	12 3/8" Product + 4 Glycol	4.0"	12"	14.0 mm	\$36



The **Foam on Beer (FOB)** Detector will immediately shut down the beer flow when a keg empties. This eliminates foam and wasted beer after a keg has “blown” because the beer lines stay full of beer at all times. Pint after pint, our **FOB** Detector has proven to be the most dependable and competitively priced stainless **FOB** on the market.

Features:

- Change kegs without wasting beer, achieving more profit from every keg
- Prevent the buildup of CO2/N2 in the beer lines; full beer lines inhibit the growth of bacteria
- Manufactured with food grade 304 stainless steel utilizing precision CNC machined components
- Benefit from self sealing vent valve and less wearing parts means a longer useful life
- Comes with male beer thread inlet and outlet ports, allowing for multiple beer line sizes to be used
- Disassembles without use of tools for ease of cleaning / service
- Threaded & stemmed fittings

*There is no need to purge a beer line that is protected with a **FOB** Detector when tapping a new keg. A **FOB** Detector will pay for itself in approximately 6 to 12 kegs by eliminating the foam that sends your profits down the drain.*

Certified by these agencies:



CUSTOMER SERVICE

Should you require more information about our products, please do not hesitate to contact our customer service team at custserv@lancerworldwide.com.



WARRANTY

For warranty specifics by product, contact your Lancer Sales Representative. Equipment design and/or specifications are subject to change without notice.

FOB Detector

FOB Detector

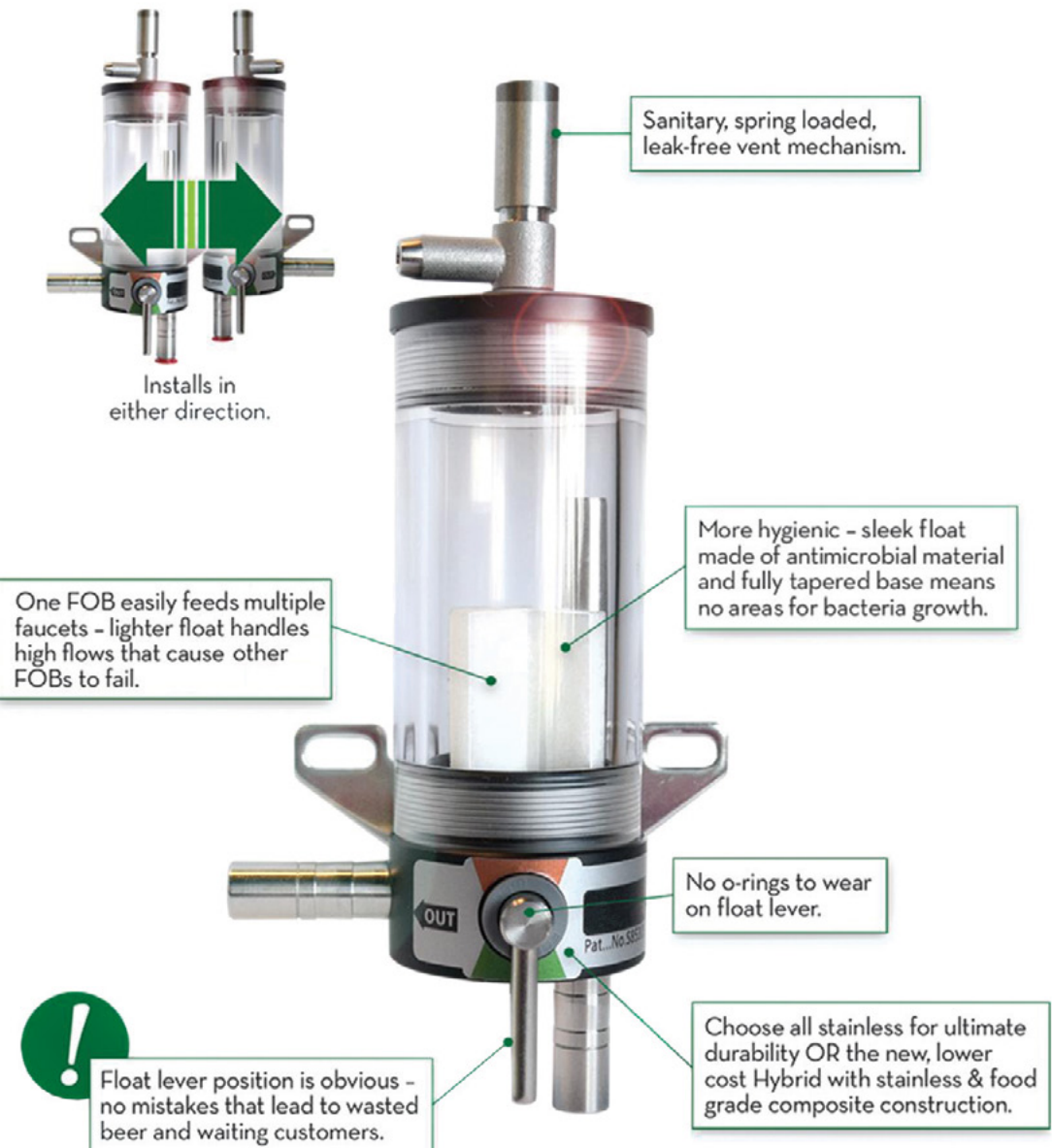



Provide CO2 or mixed gas to the keg at the right pressure, as needed. Our **Regulators** are more sensitive to gas flow, and the pressure drop required is much less than most regulators in the market.

- Maintain set pressure even while beer is flowing
- Forged brass and die cast for durability
- Adjustable knob to adjust pressure
- Base manifold and cartridges for replacement
- Available in single and double configurations
- Range: 0-60 PSI



WARRANTY

For warranty specifics by product, contact your Lancer Sales Representative. Equipment design and/or specifications are subject to change without notice.

CUSTOMER SERVICE

Should you require more information about our products, please do not hesitate to contact our customer service team at custserv@lancerworldwide.com.

Regulators

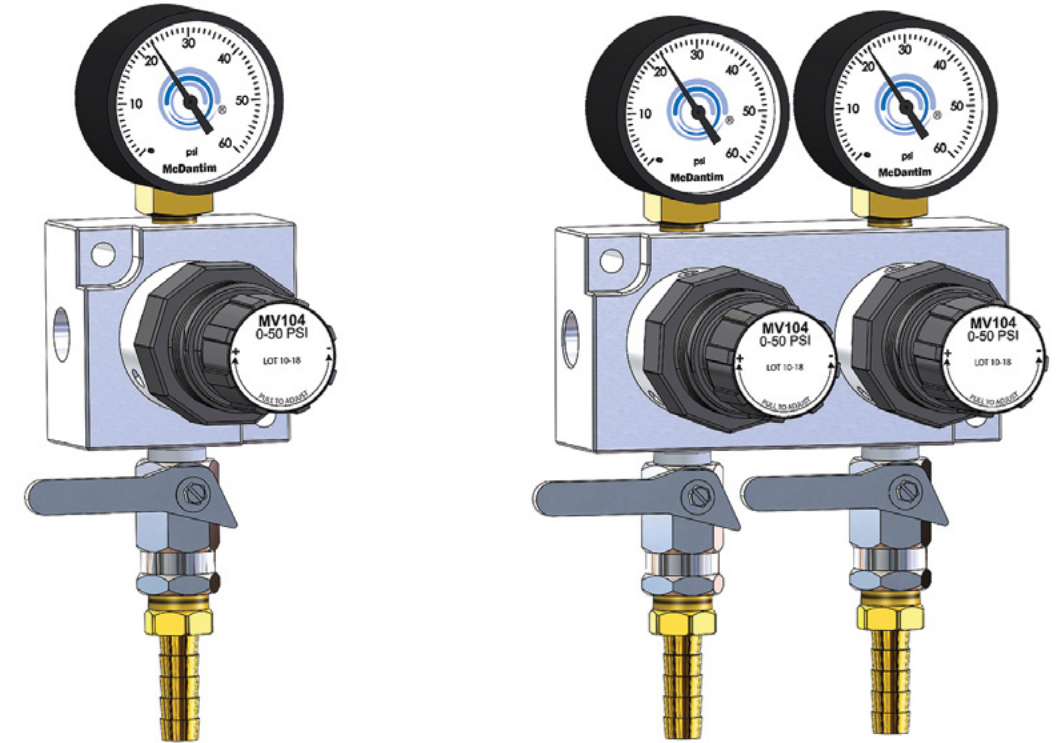

Regulators

Part #	Description	Performance
585-2R-1	Secondary TruRegs™ - Single	1 Pressure/1 Product
585-2R-2	Secondary TruRegs™ - Double	2 Pressure/2 Product
585-2R-RR	Secondary TruRegs™ - Replacement Regulator	1 Pressure/1 Product

□ 585-TM100 □ 585-TM100-HF □ 585-TM200 □ k585-TM100-HF



Gas Blenders mix CO₂ and N₂ on demand and are best used for long draw draft systems. All come preset with your custom blends to best fit your system. All panels mount easily on the wall, and are simple to install.

- Single HP **Gas Blender's** customization of the blends give you endless options and the flexibility to expand your draft beer selection.
- With the Single High Flow HPR **Gas Blender**, you are able to double the flow rate of a standard single blender at the same inlet pressure. This blender is utilized in systems where a higher flow rate is required, or higher inlet pressures, like 70 psi or 110 psi, are not feasible.
- With the Double HP **Gas Blender**, customization of the blends gives you endless options and the flexibility to expand your draft beer selection.
- With the Double High Flow HPR **Gas Blender**, you are able to include low CO₂ content nitrogenated beers, high CO₂ content German Style beers, and domestic drafts on one system without the need for additional premixed cylinders.
- Minimal pressure drops to reduce pressure issues in the line and the keg.



WARRANTY

For warranty specifics by product, contact your Lancer Sales Representative. Equipment design and/or specifications are subject to change without notice.

CUSTOMER SERVICE

Should you require more information about our products, please do not hesitate to contact our customer service team at custserv@lancerworldwide.com.

Gas Blenders

Gas Blenders

□ 585-TM100 □ 585-TM100-HF □ 585-TM200 □ k585-TM100-HF

Single Gas Blenders

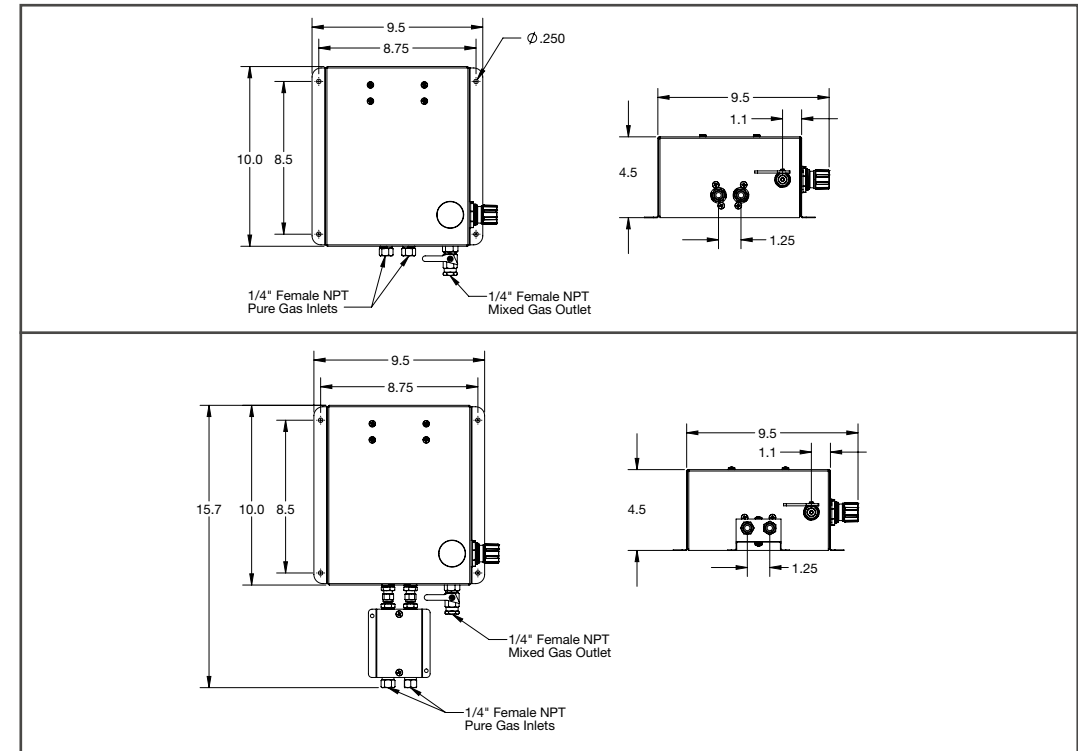

Double Gas Blenders

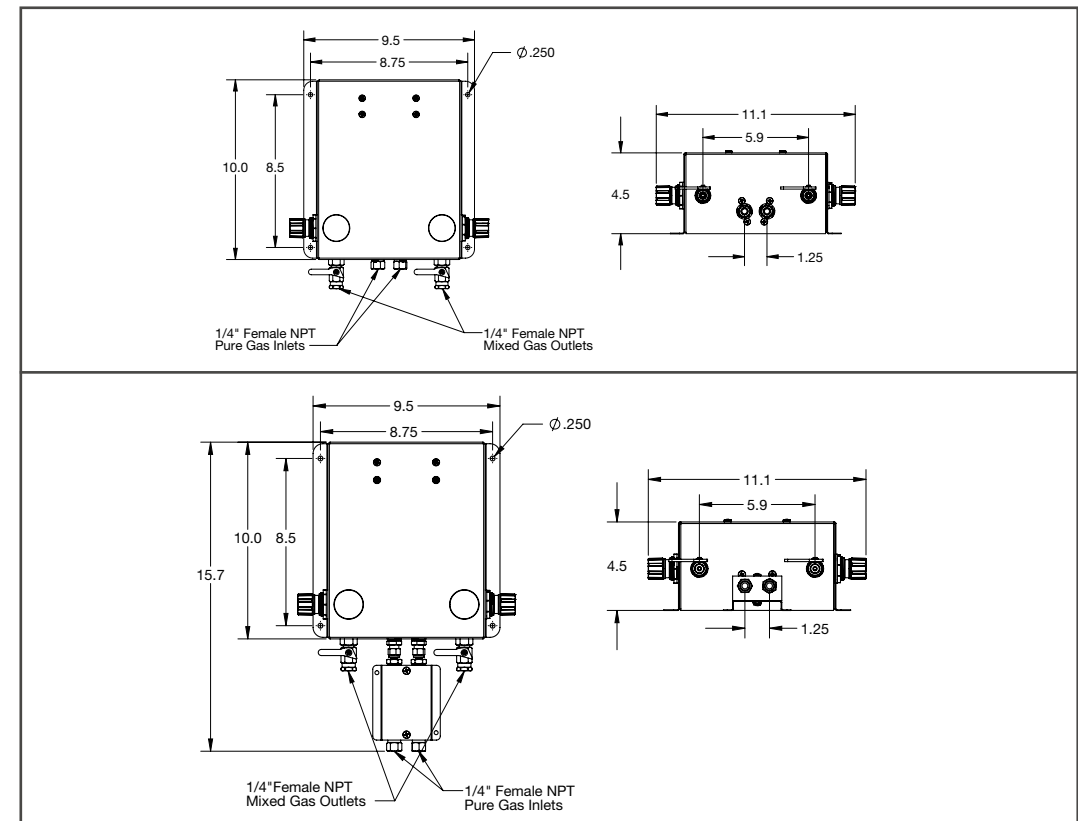



The **BreezeR Draft Dispenser** is perfect for portable bars, special events, caterers, golf clubs, micro-breweries, home use and more.

- Cold beer in a flash
- Serve cold beer from an ambient keg with a compact, appealing dispenser
- The C-tap has a separate beer pour spout and foam spout, so that creamy, long lasting foam can form on top of the beer
- Small footprint allows flexibility for placement

Accessories and Options

- CO2 cylinder
- CO2 primary regulator
- Keg coupler/tap
- Barrier beer tubing, NSF certified
- Red air supply line, NSF / FDA listed
- Fittings: hose stems, hose clamps, washers, wing nuts

Certified by these agencies:



CUSTOMER SERVICE

Should you require more information about our products, please do not hesitate to contact our customer service team at custserv@lancerworldwide.com.



WARRANTY

For warranty specifics by product, contact your Lancer Sales Representative. Equipment design and/or specifications are subject to change without notice.

BreezeR Countertop Draft Dispenser

BreezeR Countertop Draft Dispenser

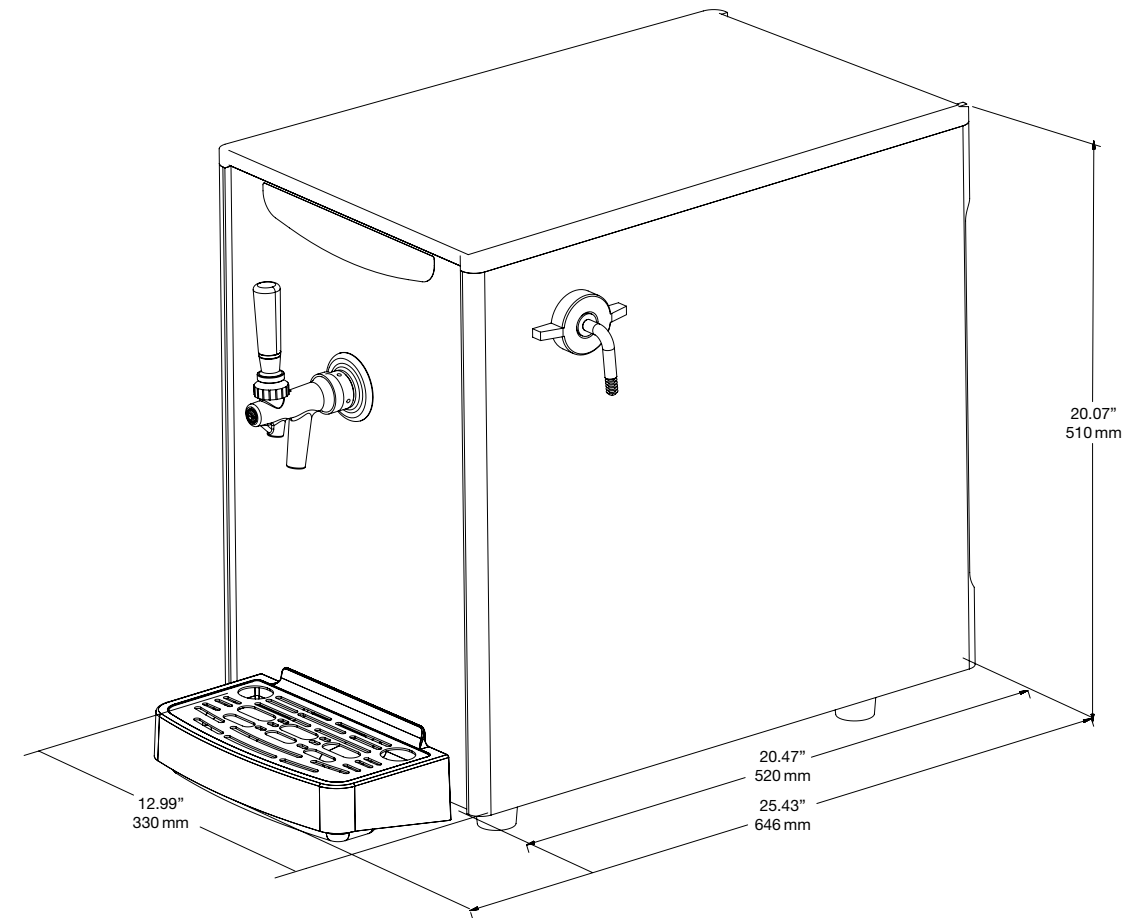

Dimensions

- Width: 12.99" (330 mm)
- Depth without drip tray: 20.47" (520 mm)
- Depth with drip tray: 25.43" (646 mm)
- Height: 20.07" (510 mm)

Weight

61.72 lbs (28 kg)

Electrical

115V 60Hz

Refrigerant

R134a

Dispensing Capacity

10.6 gal (40 L) / 4 hours

Ice Storage Capacity

17.63 lbs (10 kg)

75-51001-D



The **Breeze Draft Dispenser** serves cold beer from an ambient keg with no power, from a compact, appealing dispenser.

Perfect for portable bars, special events, caterers, golf clubs, microbreweries, home use and more.

- No power required, uses ice to cool down the beer, no refrigeration required
- Small footprint allows total flexibility for placement
- No moving parts
- Drain required for melted ice

Included items:

- Breeze beer dispenser/flash chiller
- Domestic stainless steel faucet
- Keg coupler/tap, type D or G
- CO2 primary regulator, ball valve 60 x 2,000 lbs
- 10 ft of 1/4" barrier beer tubing
- 10 ft of red air supply line
- Fittings: hose stems, hose clamps, washers, wing nuts

Required Accessories

- CO2 cylinder
- Drain required for melted ice

Options

- C-Tap Faucet

Certified by these agencies:



CUSTOMER SERVICE

Should you require more information about our products, please do not hesitate to contact our customer service team at custserv@lancerworldwide.com.



WARRANTY

For warranty specifics by product, contact your Lancer Sales Representative. Equipment design and/or specifications are subject to change without notice.

Breeze Countertop Draft Dispenser

Breeze Countertop Draft Dispenser

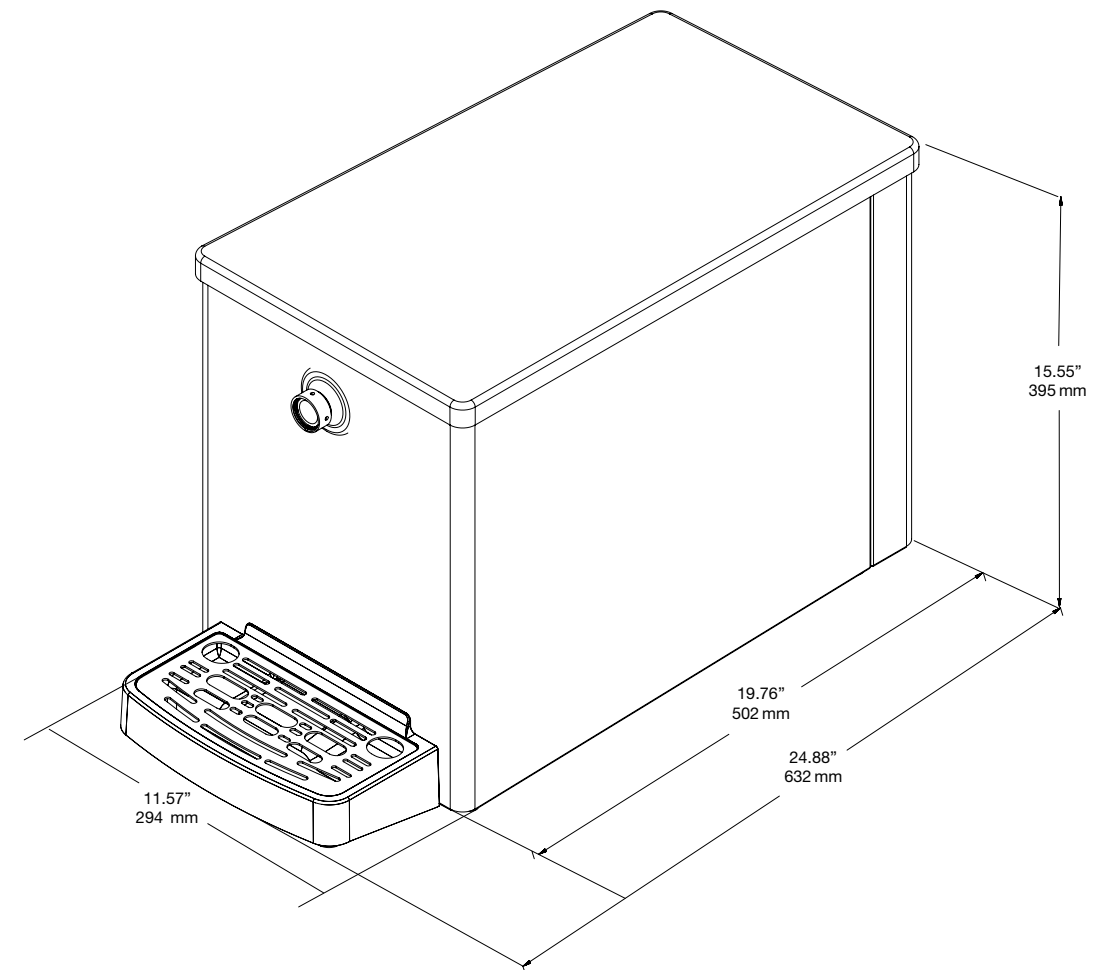

Dimensions

- Width: 11.57" (294mm)
- Depth without drip tray: 19.76" (502mm)
- Depth with drip tray: 24.88" (632mm)
- Height: 15.55" (395mm)

Weight

63.93 lbs (29kg)

Ice Storage Capacity

22.04 lbs (10kg)

LANCER[®]
W O R L D W I D E

lanceworldwide.com