



SPECIALTY

COLLECTION

 **DISPLAYS**
Cayuga





DEPARTMENT: SPECIALTY

When you add those specialty functions in your retail space you increase sales, but you also enhance the overall brand impression of your store.

Don't let the product - rich center areas or your store go under - utilized. Grocery display needs to do more than present for efficiency and visibility. In this area it's all about bringing maximum interest and energy to the inner square footage..

Perhaps it's a popular soup and salad bar or a focal area of gondola shelving. Let's talk about all of the options. We'll help you find the right unit - or combination of units - to inject excitement and interest on you floor.

We'll help you develop your central zone to achieve the product attention and customer experience that will translate to product sales and customer loyalty

"Cayuga has always provided us with sensible and reliable options and have always exceeded our expectations in customer service.."

Neil Forth
Neelands Refrigeration
Sales

"Cayuga creates VALUE for us and their design team is great to work with. Some people may call their product fixtures but I call it furniture."

Noah Katz
Foodtown PSK
Owner

Table of Contents

Wall Shelving	5
Bookcase Style Shelving	7
Shop Around Shelving Display	8
Crate Style Shop Around Display	9
Bulk Bin Gondola Display	10
Nesting Table Sets	
Nesting Table Set - 7 Piece	11
Nesting Table Set - 3 Piece	12
Stepped Nesting Table Set - 5 Piece	13
Stepped Nesting Table Set - 4 Piece	14
Stepped Nesting Table Set - 3 Piece	15
Markte Bin	
Market Bin w/Base Merchandising	17
Market Bin	18
Wing Table - 3 Open Sides	19
Closed Wing Table	20
Demo Carts	21
Impulse Merchandising Display	22
Metal Wing Base	23
General Merchandising Tables	24
Wire Cage for 3' Tables	25
Case Kicker	26
Cash End Displays	27
Finishes	
Laminate	29
Painted Metal	31
Wood Stains	32
How to Order	33

WALL SHELVING



Finish: Natural Maple

13' 10"L Shelving shown:
SDCT-005-02B (36" Wall Shelving)
SDCT-005-02B (36" Wall Shelving)
SDCT-005-01B (48" Wall Shelving)
SDCT-005-01B (48" Wall Shelving)



Finish: Weathered Wood

6' 11"L Shelving shown:
SDCT-005-02B (36" Wall Shelving)
SDCT-005-01B (48" Wall Shelving)

Applications

- These modular shelving displays can be easily configured to create a continuous run
- Adjustable shelves on metal brackets
- ABS bumper & PTM available upon request

WALL SHELVING



Clear finish shown



Oiled Cherry finish shown. Other finishes available - see chart.

MODEL	DESCRIPTION	LENGTH	DEPTH	HEIGHT
SDCT-005-01B	Wall Shelving - 48"	47 ½"	20"	86"
SDCT-005-02B	Wall Shelving - 36"	35 ½"	20"	86"

FEATURES:

- Birch/maple plywood and solid maple construction
- Adjustable shelves on metal brackets

OPTIONS:

- Refer to Wood Stains Finishes

NOT FREESTANDING UNIT, DESIGNED TO BE FASTENED TO WALL

Note: Information and specifications may change due to engineering improvements.

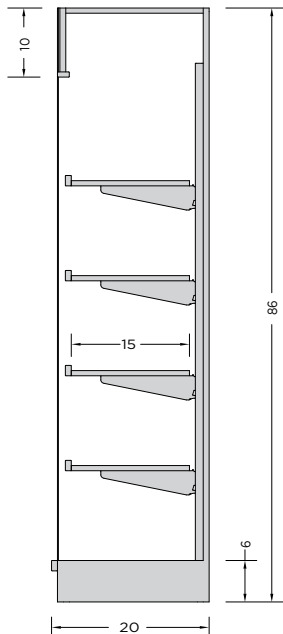

SDCT-005-01B (47 ½"L) &
SDCT-005-02B (35 ½"L)

BOOKCASE STYLE SHELVING



Clear finish shown



Danish Walnut finish shown. Other finishes available - see chart.

MODEL	DESCRIPTION	LENGTH	DEPTH	HEIGHT
SDBS-021-01B	Bookcase Style Shelving - 48"	48"	15 ¾"	77 ¼"

FEATURES:

- Birch/maple plywood and solid maple construction
- Adjustable shelves on Pilasters

OPTIONS:

- Refer to Wood Stains Finishes

NOT FREESTANDING UNIT, DESIGNED TO BE FASTENED TO WALL

Note: Information and specifications may change due to engineering improvements.

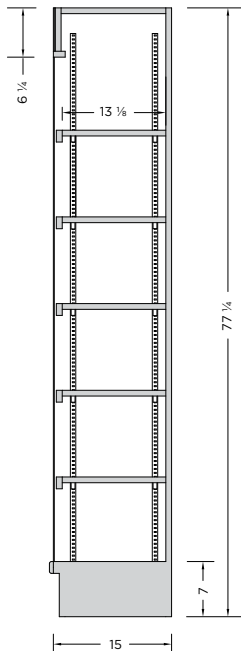

SDBS-021-01B

SHOP AROUND SHELVING DISPLAY

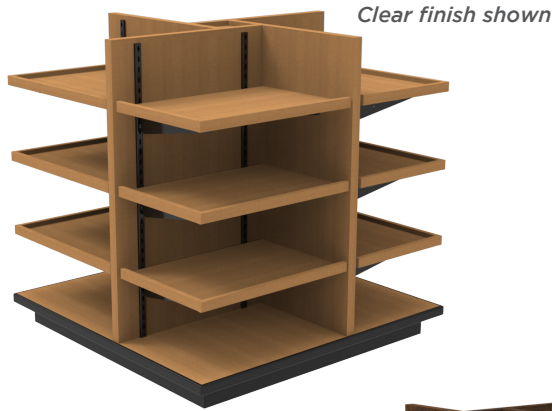

Choco Cherry finish shown. Other finishes available - see chart.

MODEL	DESCRIPTION	LENGTH	DEPTH	HEIGHT
SDSA-011-01B	Shop Around Shelving - 48"	49"	49"	48 ¾"
SDSA-012-01B	Shop Around Shelving - 41"	42"	42"	48 ¾"
SDSA-013-01B	Shop Around Shelving - 37"	38"	38"	48 ¾"

FEATURES:

- Birch/maple plywood and solid maple construction
- Levelers
- Bumper
- Adjustable shelves

OPTIONS:

- McCue bumper & PTM
- Refer to Wood Stains Finishes

Note: Information and specifications may change due to engineering improvements.

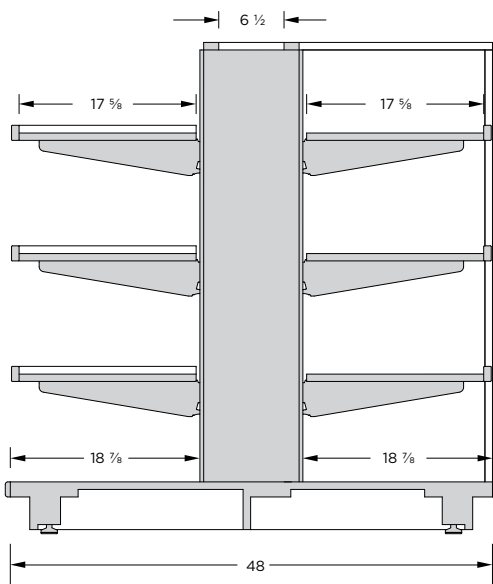

SDSA-011-01B

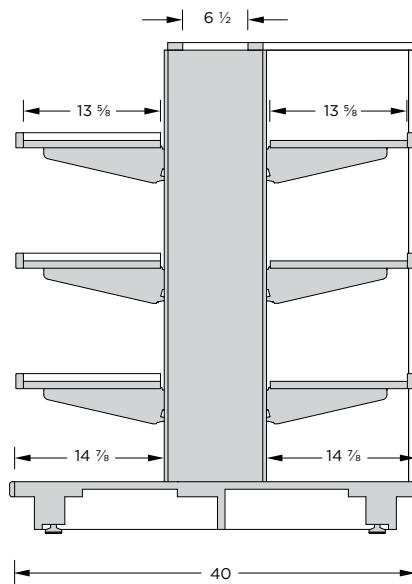

SDSA-012-01B

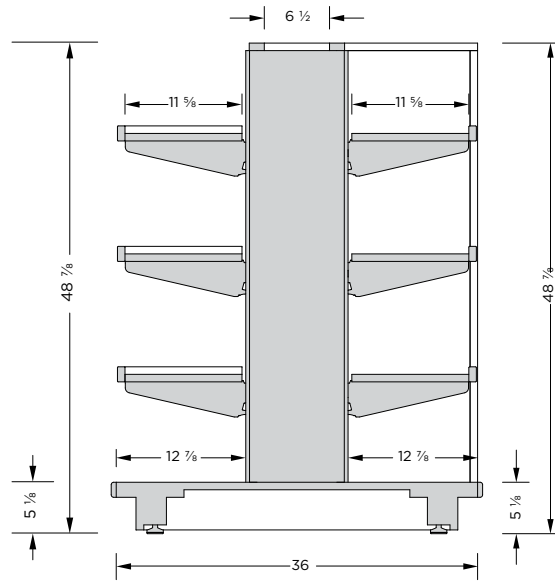

SDSA-013-01B

CRATE STYLE SHOP AROUND DISPLAY



Clear finish shown



Weathered Wood finish shown. Other finishes available - see chart.

MODEL	DESCRIPTION	LENGTH	DEPTH	HEIGHT
SDSA-006-01B	Crate Style Shop Around	36 1/4"	36 1/4"	50"

FEATURES:

- Birch/maple plywood construction
- Heavy duty locking casters
- Bumper
- Sign track on all 4 sides for posters
- ABS shelf liner

OPTIONS:

- Refer to Wood Stains Finishes

Note: Information and specifications may change due to engineering improvements.

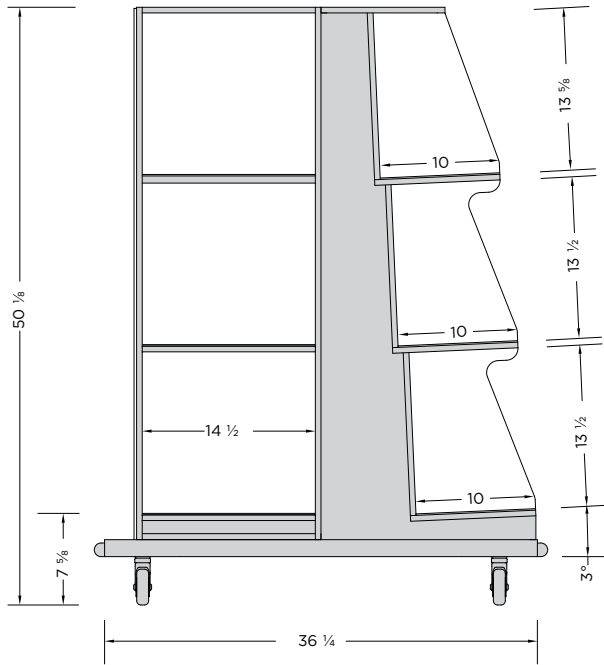

SDSA-006-01B

BULK BIN GONDOLA DISPLAY



Clear finish shown



Weathered Wood finish shown. Other finishes available - see chart.

MODEL	DESCRIPTION	LENGTH	DEPTH	HEIGHT
BFBK-001-01B	Bulk Bin Gondola Display - 61"	61 ¼"	25 ¾"	49 ¾"
BFBK-001-02B	Bulk Bin Gondola Display - 49"	49 ¼"	25 ¾"	49 ¾"

FEATURES:

- Birch/maple plywood, MDF and solid maple construction
- Pull out drawer
- Heavy duty locking and non-locking casters
- Individual bins w/ scoops

OPTIONS:

- Bag holder and signage also available
- ABS bumper or McCue
- Refer to Wood Stains Finishes

Note: Information and specifications may change due to engineering improvements.

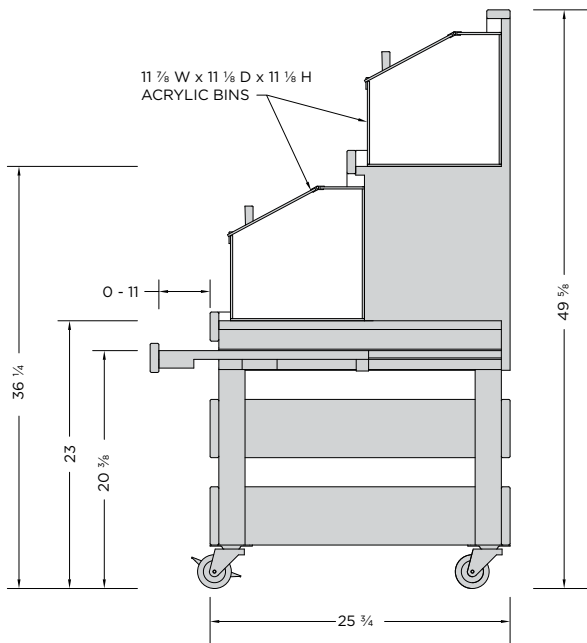

BFBK-001-01B (61 ¼"L) & BFBK-001-02B (49 ¼"L)

NESTING TABLE SET

7 PIECE

Clear finish shown



Weathered Wood finish w/optional corner guards & bumper shown. Other finishes available - see chart.

MODEL	DESCRIPTION	LENGTH	DEPTH	HEIGHT
TBST-012-01J	7 Piece Nesting Table Set			
TBHV-027-01E	Nesting Table - Large	36"	36"	35 1/2"
TBHV-028-01E	Nesting Table with Shelf - Small	27"	27"	28 1/2"
TBHV-029-01E	Bench Table with Shelf	47 3/8"	12"	28 1/2"
ACRI-006-01A	Riser	36"	14"	7"

FEATURES:

- Birch/maple plywood & solid maple construction
- Nylon glide
- Protective leg caps
- Fixed base shelf on side tables

OPTIONS:

- Corner guards & ABS bumper
- Refer to Wood Stains Finishes

Note: Information and specifications may change due to engineering improvements.

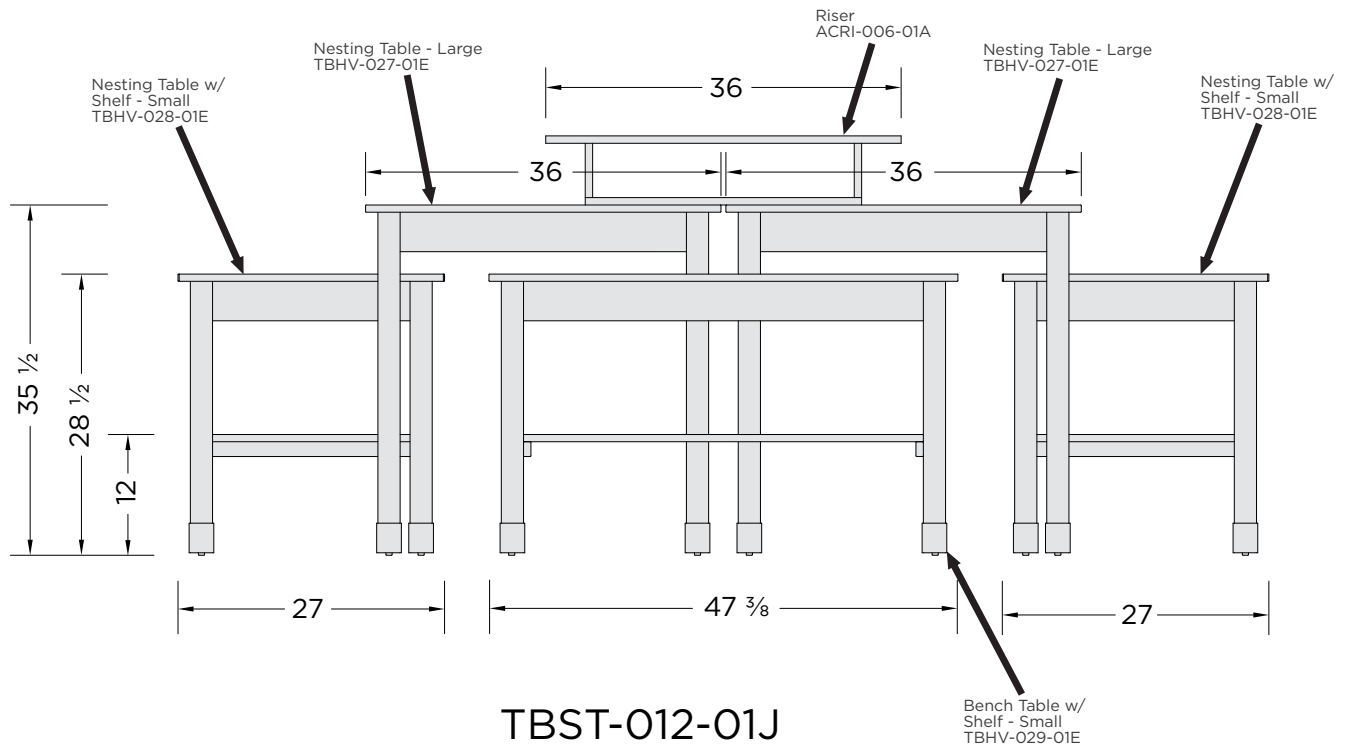

NESTING TABLE SET

3 PIECE



MODEL	DESCRIPTION	LENGTH	DEPTH	HEIGHT
TBST-011-01K	3 Piece Nesting Table Set			
TBHV-030-01E	Nesting Table - Large	47 1/2"	23 1/2"	36"
TBHV-031-01E	Nesting Table w/ Shelf - Small	39 1/2"	18 1/2"	30"

FEATURES:

- Birch/maple plywood & solid maple construction
- Nylon glide
- Protective leg caps
- Fixed base shelf on side tables

OPTIONS:

- Corner guards & ABS bumper
- Refer to Wood Stains Finishes

Note: Information and specifications may change due to engineering improvements.

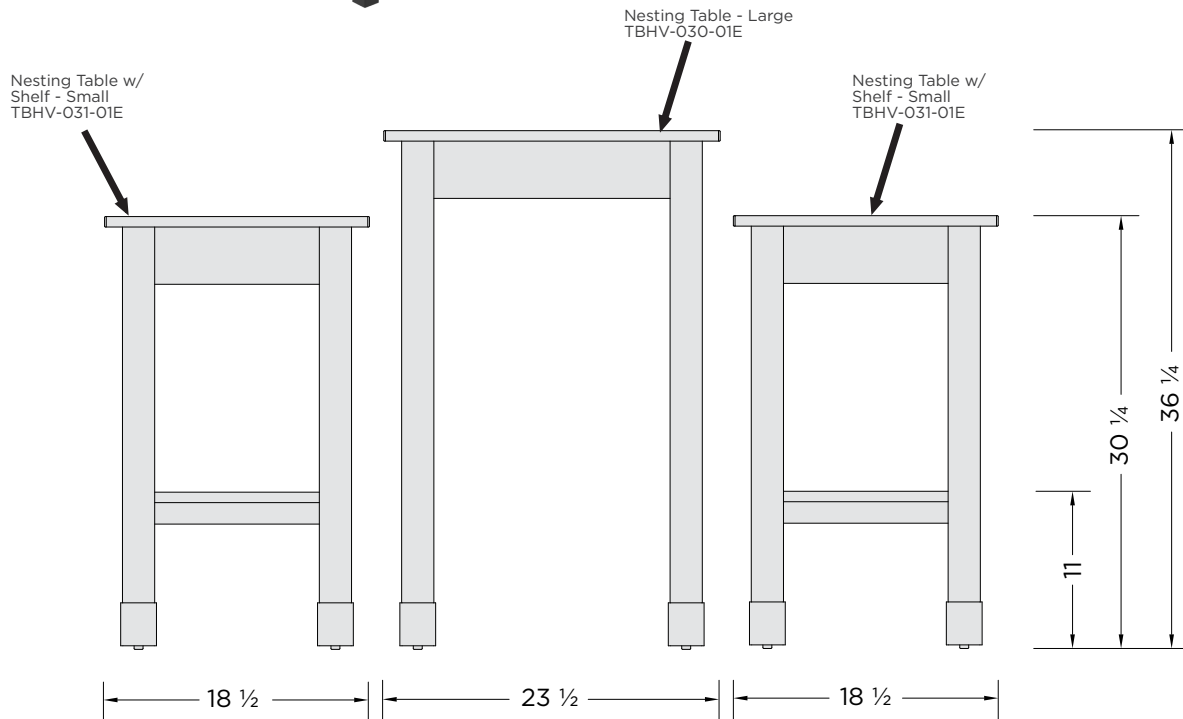

TBST-011-01K

STEPPED NESTING TABLE SET

5 PIECE

Clear finish shown



Select Cherry finish w/ optional corner guards & bumper shown. Other finishes available - see chart.

MODEL	DESCRIPTION	LENGTH	DEPTH	HEIGHT
TBST-011-01M	5 Piece Nesting Table Set			
TBHV-030-01E	Nesting Table - Large	47 1/2"	23 1/2"	36"
TBHV-035-01E	Nesting Table - Medium	38 1/2"	23 1/2"	29 3/4"
TBHV-046-01E	Nesting Table - Small	29 1/2"	23 1/2"	23 1/2"

FEATURES:

- Birch/maple plywood & solid maple construction
- Nylon glide
- Protective leg caps
- Fixed base shelf on side tables

OPTIONS:

- Corner guards & ABS bumper
- Refer to Wood Stains Finishes

Note: Information and specifications may change due to engineering improvements.

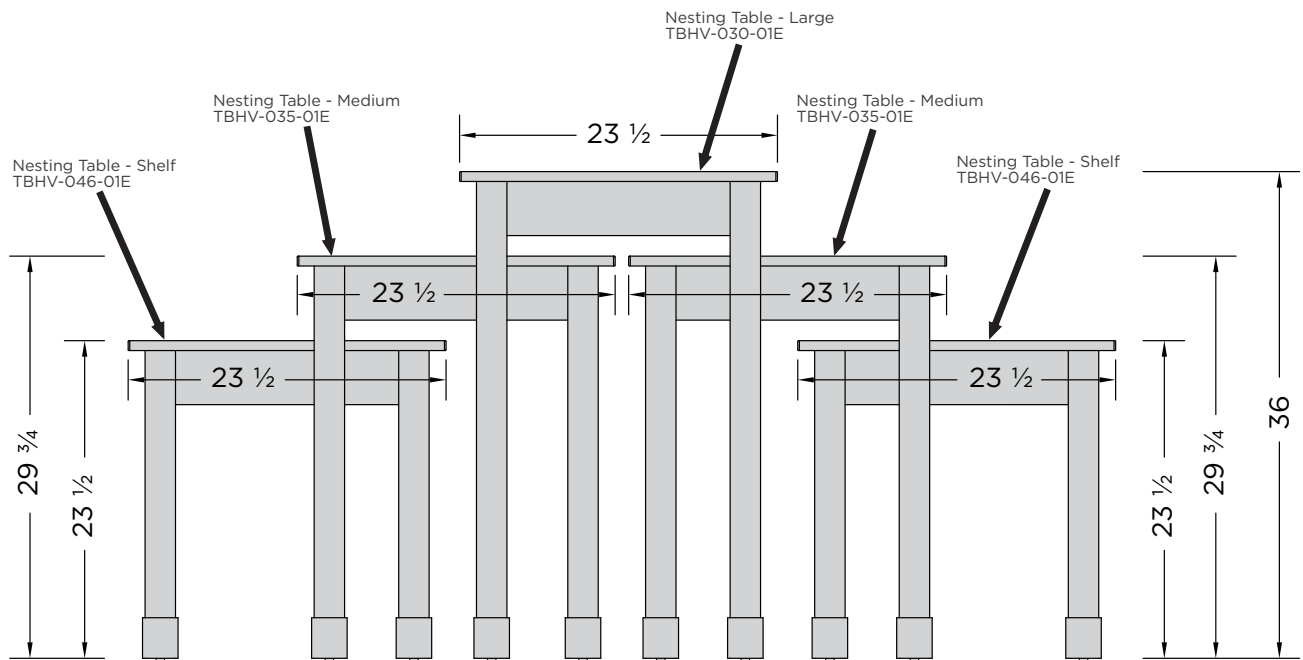

TBST-011-01M

STEPPED NESTING TABLE SET

4 PIECE



Clear finish shown



Select Cherry finish w/ optional corner guards & bumper shown. Other finishes available - see chart.

MODEL	DESCRIPTION	LENGTH	DEPTH	HEIGHT
TBST-012-01K	4 Piece Nesting Table Set			
TBHV-034-01E	Nesting Table - Large	47 ½"	47 ½"	36"
TBHV-036-01E	Nesting Table with Shelf - Medium	38 ½"	23 ½"	30"
ACRI-007-01A	Riser	18"	12"	10"

FEATURES:

- Birch/maple plywood & solid maple construction
- Nylon glide
- Protective leg caps
- Fixed base shelf on side tables

OPTIONS:

- Corner guards & ABS bumper
- Refer to Wood Stains Finishes

Note: Information and specifications may change due to engineering improvements.

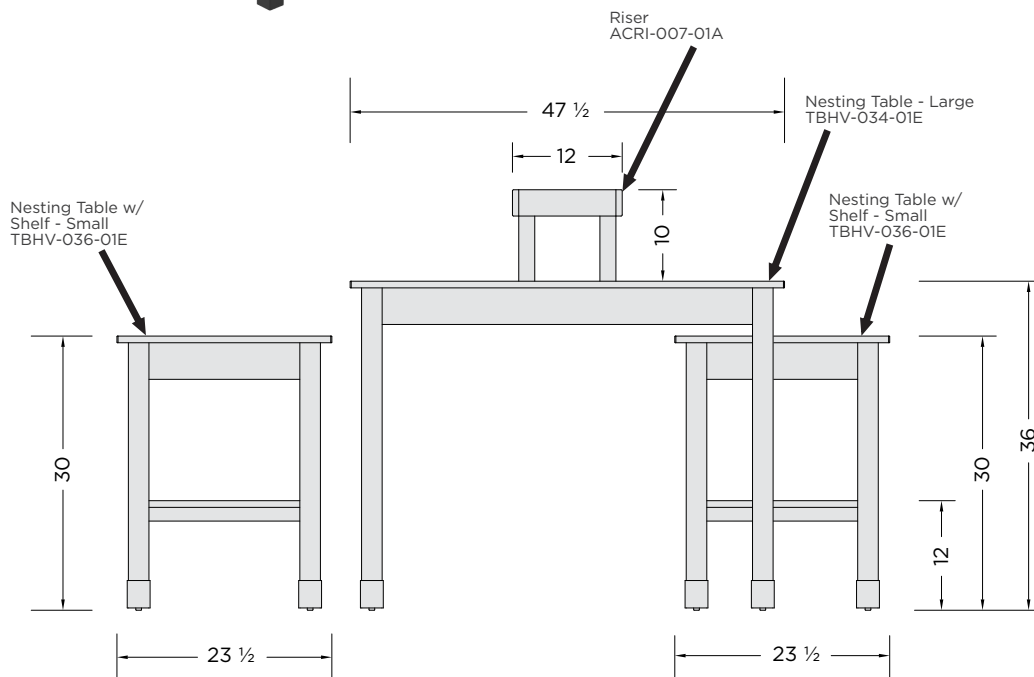

TBST-012-01K

STEPPED NESTING TABLE SET

3 PIECE



Clear finish shown



Oiled Cherry finish w/ optional corner guards & bumper shown. Other finishes available - see chart.

MODEL	DESCRIPTION	LENGTH	DEPTH	HEIGHT
TBST-011-01L	3 Piece Nesting Table Set			
TBHV-030-01E	Nesting Table - Large	47 1/2"	23 1/2"	36"
TBHV-035-01E	Nesting Table - Medium	38 1/2"	23 1/2"	29 3/4"
TBHV-046-01E	Nesting Table - Small	29 1/2"	23 1/2"	23 1/2"

FEATURES:

- Birch/maple plywood & solid maple construction
- Nylon glide
- Protective leg caps

OPTIONS:

- Corner guards & ABS bumper
- Refer to Wood Stains Finishes

Note: Information and specifications may change due to engineering improvements.

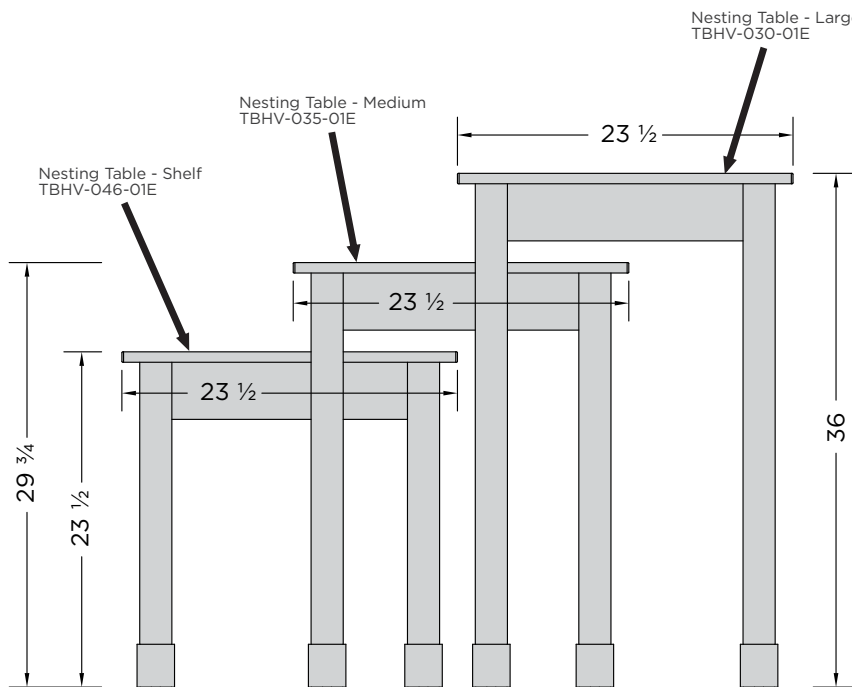

TBST-011-01L

MARKET BIN

Finish: Select Cherry



11' 11" L Market Bin shown:
 TBOR-060-01C (Market Bin)
 TBOR-063-01C (Market Bin w/Wire Cage)
 TBOR-061-01C (Market Bin w/Wire Cage)
 TBOR-062-01C (Market Bin)

Finish: Natural Maple



Finish: Weathered Wood



5' 11 1/2" L Market Bin shown:
 TBOR-061-01C (Market Bin w/ABS Liner)
 TBOR-061-01C (Market Bin w/ABS Liner)
 TBOR-078-01B (Wing Table w/ABS Liner)

8' 11 1/4" L Market Bin shown:
 TBOR-062-01C (Market Bin w/ABS Liner)
 TBOR-079-01B (Wing Table w/ABS Liner)
 TBOR-079-01B (Wing Table w/ABS Liner)
 TBOR-063-01C (Market Bin w/ABS Liner)
 TBOR-063-01C (Market Bin w/ABS Liner)
 TBOR-079-01B (Wing Table w/ABS Liner)
 TBOR-079-01B (Wing Table w/ABS Liner)

Applications

- The market bin collection can be stand-alone, line-up or island configurations

MARKET BIN WITH BASE MERCHANDISING



Clear finish shown



Select Cherry finish w/
optional wire cage shown.
Other finishes available -
see chart.

MODEL	DESCRIPTION	LENGTH	DEPTH	HEIGHT
TBOR-062-01C	Market Bin	35 3/4"	35 3/4"	31 3/4"
TBOR-063-01C	Market Bin - Tall	35 3/4"	35 3/4"	35 3/4"

FEATURES:

- Birch/maple plywood, solid maple, melamine and MDF construction
- Heavy duty casters (2 locking)
- Corner guards

OPTIONS:

- ABS haircell liner
- Wire cage
- 1 1/2" ABS bumper
- Refer to Wood Stains Finishes

Note: Information and specifications may change due to engineering improvements.

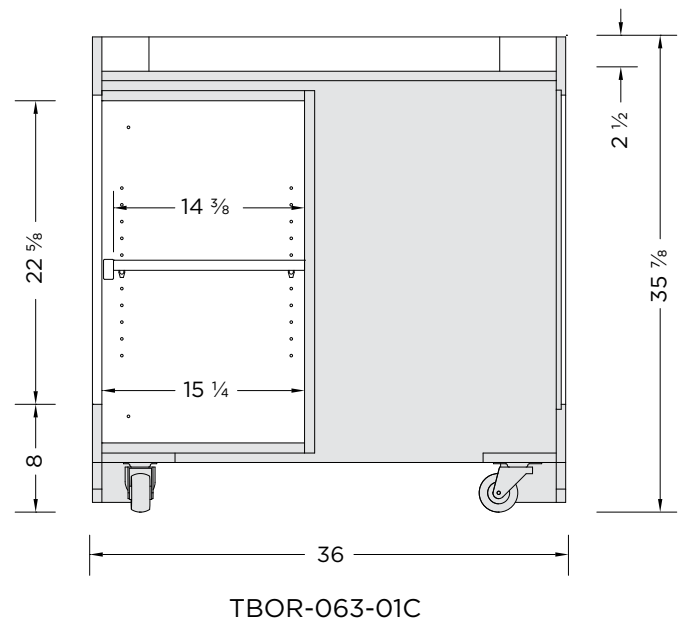
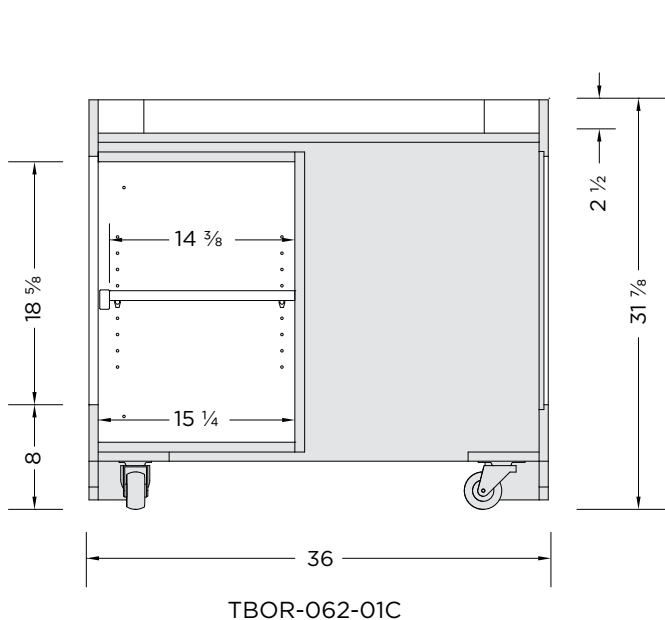

MARKET BIN

Clear finish shown



Weathered Wood finish w/ optional ABS liner shown. Other finishes available - see chart.

MODEL	DESCRIPTION	LENGTH	DEPTH	HEIGHT
TBOR-060-01C	Market Bin	35 3/4"	35 3/4"	31 3/4"
TBOR-061-01C	Market Bin - Tall	35 3/4"	35 3/4"	35 3/4"

FEATURES:

- Birch/maple plywood and MDF construction
- Heavy duty casters (2 locking)
- Corner guards

OPTIONS:

- ABS haircell liner
- Wire cage
- 1 1/2" ABS bumper
- Refer to Wood Stains Finishes

Note: Information and specifications may change due to engineering improvements.

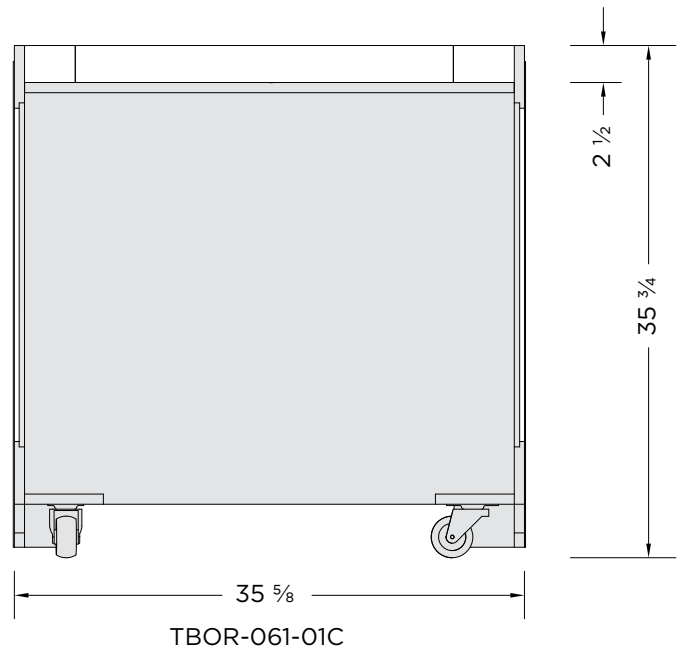
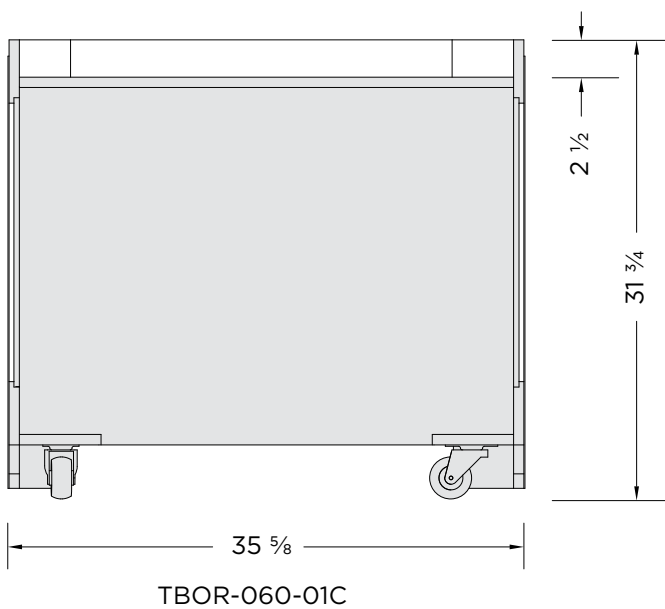

WING TABLE - 3 OPEN SIDES



Oiled Cherry finish w/
optional ABS liner shown.
Other finishes available -
see chart.

MODEL	DESCRIPTION	LENGTH	DEPTH	HEIGHT
TBOR-078-01B	Wing Table - 3 Open Sides	34 7/8"	17 7/8"	31 1/4"

FEATURES:

- Birch/maple plywood and solid maple construction
- Adjustable shelf on shelf pins
- Protective corner guards

OPTIONS:

- ABS haircell liner
- 1 1/2" ABS bumper
- Refer to Wood Stains Finishes

Note: Information and specifications may change due to engineering improvements.

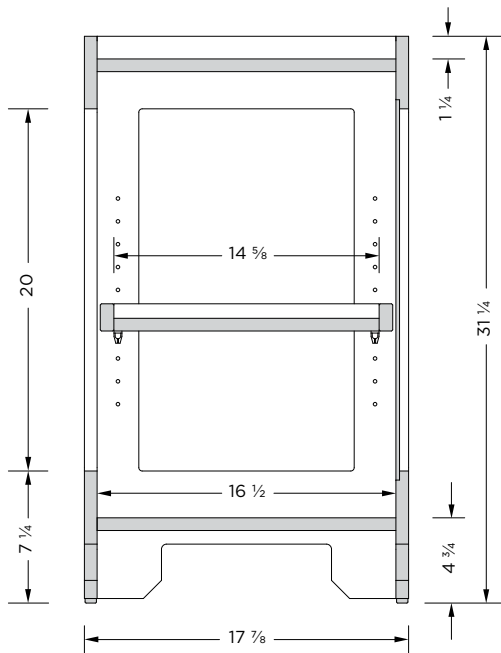

TBOR-078-01B

CLOSED WING TABLE



MODEL	DESCRIPTION	LENGTH	DEPTH	HEIGHT
TBOR-079-01B	Closed Wing Table	34 7/8"	17 7/8"	31 1/4"

FEATURES:

- Birch/maple plywood and solid maple construction
- Adjustable shelf on shelf pins
- Protective corner guards

OPTIONS:

- ABS haircell liner
- 1 1/2" ABS bumper
- Refer to Wood Stains Finishes

Note: Information and specifications may change due to engineering improvements.

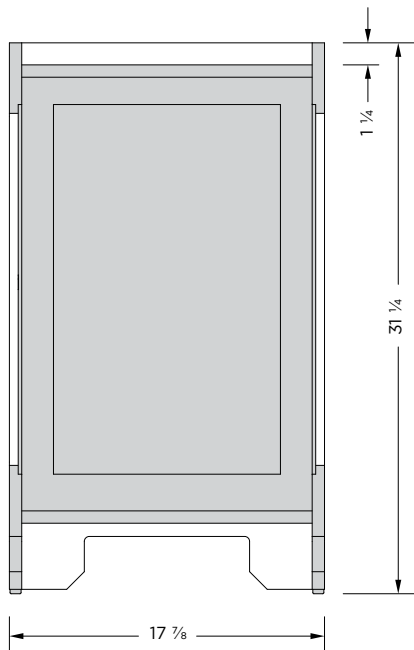

TBOR-079-01B

DEMO CART



Clear finish shown



Concerto finish shown. Other finishes available - see chart.

MODEL	DESCRIPTION	LENGTH	DEPTH	HEIGHT
CRDC-001-01B	Demo Cart w/ Rear Storage - 48"	47 ¾"	23 ¾"	35"
CRDC-003-01B	Demo Cart w/ Fold Down Shelves - 48"	48"	18 ½"	62"

FEATURES:

- CRDC-001-01B
 - Birch/maple plywood construction w/ T-mold and ABS bumper
 - Rear storage w/ sliding door
- CRDC-003-01B
 - Birch/maple plywood and solid maple construction
 - Fold down side shelves and pull out shelf
- Locking casters

OPTIONS:

- Refer to Wood Stains Finishes

Note: Information and specifications may change due to engineering improvements.

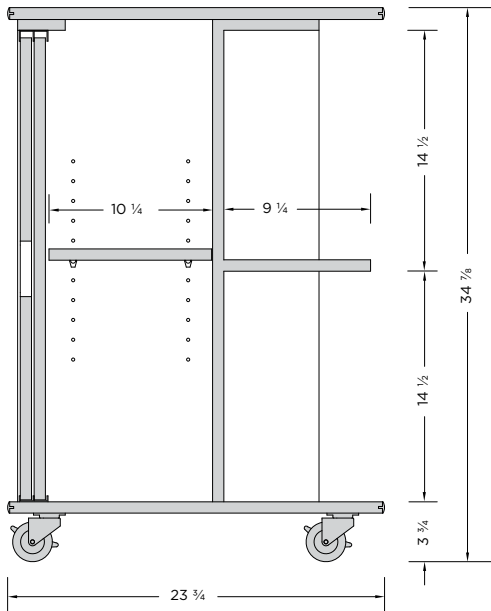

CRDC-001-01B

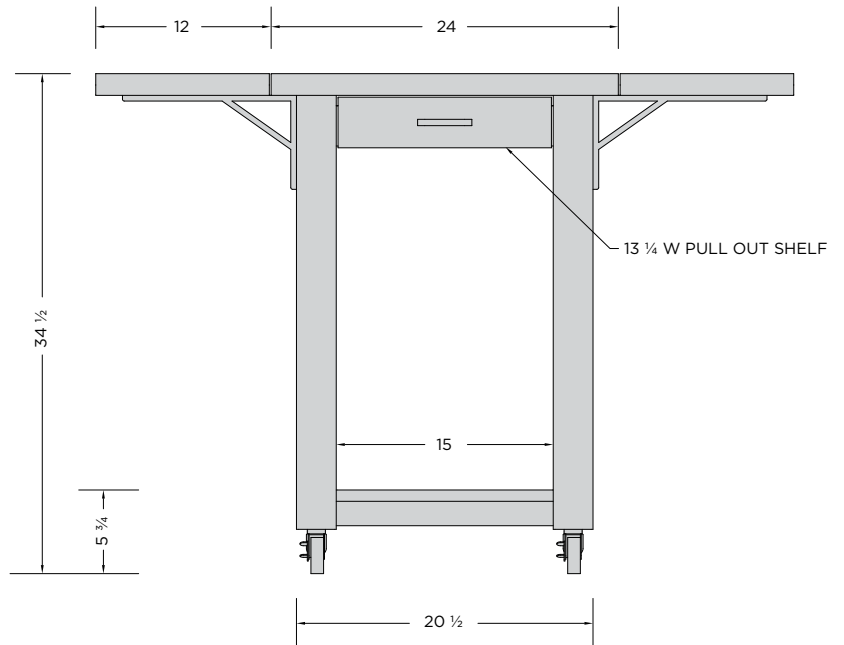

CRDC-003-01B

IMPULSE MERCHANDISING DISPLAY



Clear finish shown

SDCS-013-01B



SPIM-009-01A

Weathered Wood finish shown. Other finishes available - see chart.

MODEL	DESCRIPTION	LENGTH	DEPTH	HEIGHT
SDCS-013-01B	Impulse Merch w/ Adj. Shelves	24"	22 ¾"	49 ⅜"
SPIM-009-01A	Impulse Merch w/ Solid Gables	24"	20"	60"

FEATURES:

- SPIM-009-01A
 - Birch/maple plywood construction
- SPIM-009-01A
 - Birch/maple plywood and solid maple construction
 - Adjustable shelves, ABS bumper & locking casters

OPTIONS:

- PTM
- Tack glides available for SPIM-009-01A
- Refer to Wood Stains Finishes

Note: Information and specifications may change due to engineering improvements.

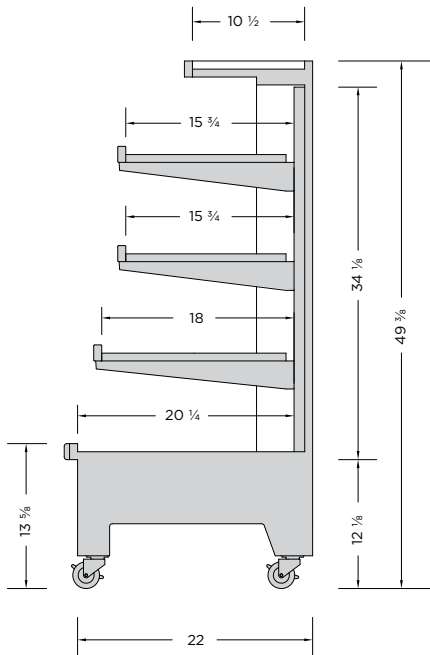

SDCD-013-01B

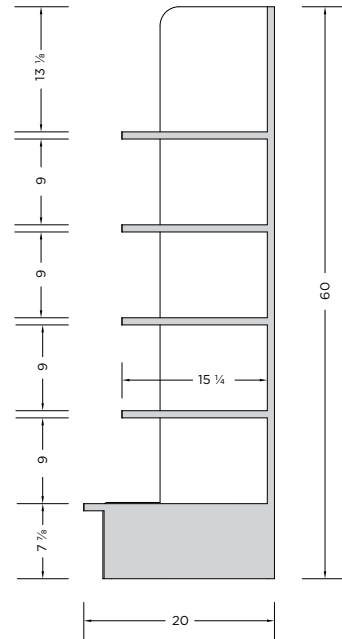

SPIM-009-01A

METAL WING BASE



Powder Coated Black finish shown

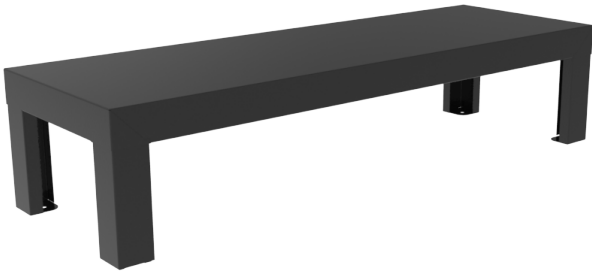

MODEL	DESCRIPTION	LENGTH	DEPTH	HEIGHT
ACWG-006-01B	Metal Wing Bases - 36"	36"	12"	8"
ACWG-007-01B	Metal Wing Bases - 18"	18"	12"	6"
ACWG-008-01B	Metal Wing Bases - 24"	24"	12"	6"

FEATURES:

- Metal construction powder coated black

Note: Information and specifications may change due to engineering improvements.

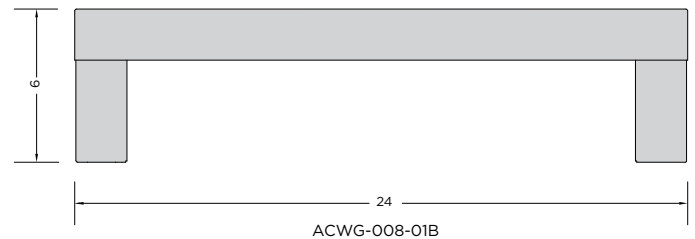
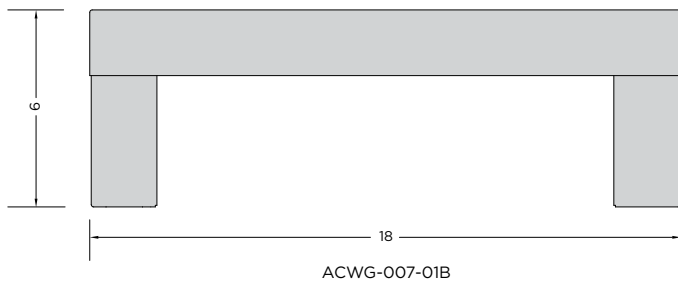
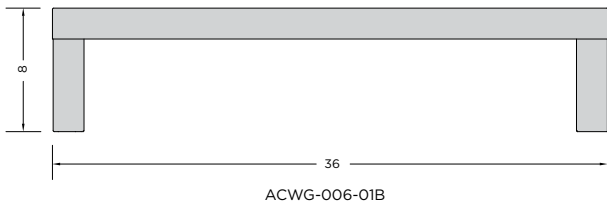

GENERAL MERCHANDISING TABLES



Clear finish shown



Choco Cherry finish shown. Other finishes available - see chart.

MODEL	DESCRIPTION	LENGTH	DEPTH	HEIGHT
TBDP-005-02B	General Merch. Tables - 36"	36"	36"	30 ¾"

FEATURES:

- Birch/maple plywood, Melamine and solid maple construction
- Levelers

OPTIONS:

- Wire cage
- 1 ½" ABS bumper
- Protective corners
- Refer to Wood Stains Finishes

Note: Information and specifications may change due to engineering improvements.

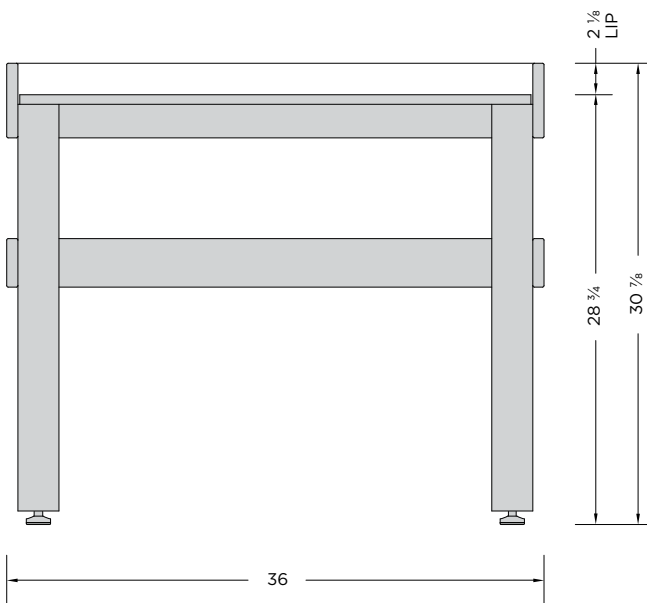

TBDP-005-01B

WIRE CAGE

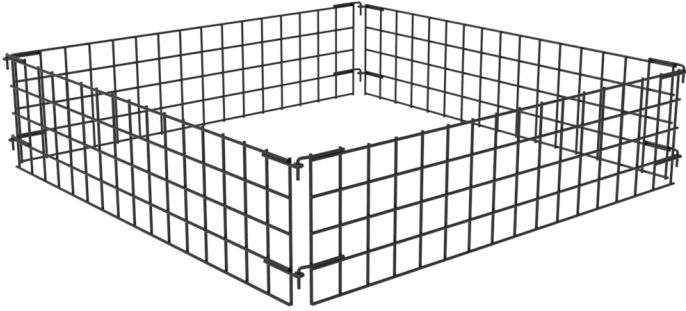

MODEL	DESCRIPTION	LENGTH	DEPTH	HEIGHT
ACPS-011-01A	Wire Cage for 3' Table	33 7/8"	33 7/8"	8 1/8"

FEATURES:

- Metal construction powder coated black

Note: Information and specifications may change due to engineering improvements.

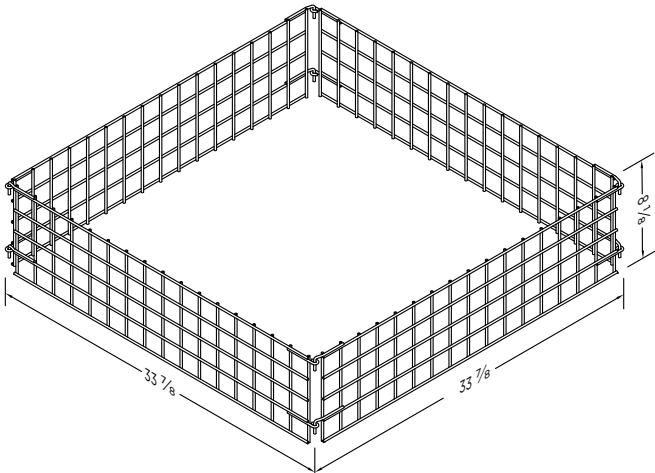

ACPS-011-01A



CASE KICKER



Clear finish shown



Danish Walnut finish shown. Other finishes available - see chart.

MODEL	DESCRIPTION	LENGTH	DEPTH	HEIGHT
SPCK-003-01E	Case Kicker - 49"	48 ½"	14 ½"	24"
SPCK-003-02E	Case Kicker - 37"	36 ½"	14 ½"	24"

FEATURES:

- Birch/maple plywood & solid maple construction
- Adjustable shelf on pilasters
- Bumper

OPTIONS:

- Refer to Wood Stains Finishes

Note: Information and specifications may change due to engineering improvements.

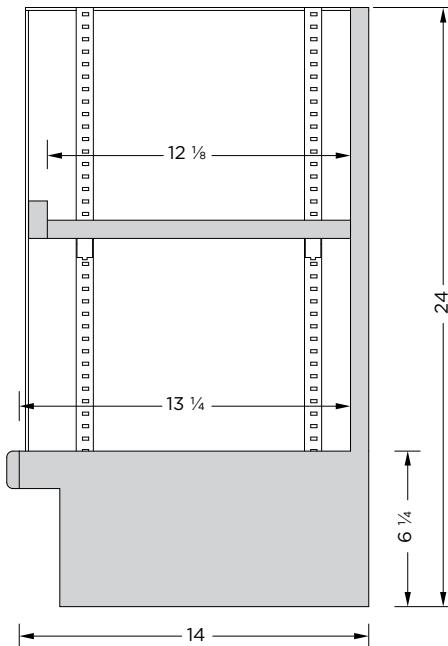

SPCK-003-01E (48 ½"L) & SPCK-003-02E (36 ½"L)

CASH END DISPLAYS



Clear finish shown



Choco Cherry finish shown. Other finishes available - see chart.

MODEL	DESCRIPTION	LENGTH	DEPTH	HEIGHT
SDCO-003-01B	Cash End Display- 48"	48 ½"	25"	54"
SDCO-004-01B	Cash End Display- 53"	52 ⅝"	23"	55"
SDCO-005-01B	Cash End Display- 48"	48"	18 ½"	62"
SDCO-006-01B	Cash End Display- 50"	50 ¼"	23"	55"

FEATURES:

- Birch/maple plywood and solid maple construction
- Slatwall w/ black metal inserts
- ABS bumper

OPTIONS:

- Slatwall shelves, hooks & literature holders
- McCue bumper & PTM
- Refer to Wood Stains Finishes

Note: Information and specifications may change due to engineering improvements.

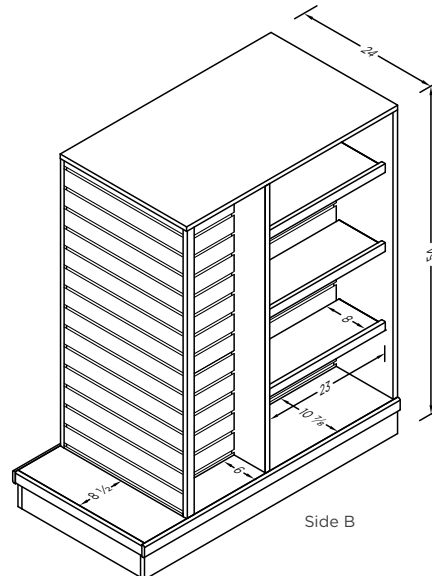
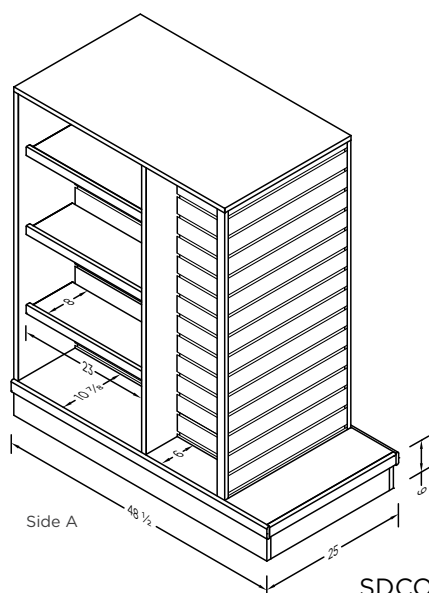

SDCO-003-01B

CASH END DISPLAYS

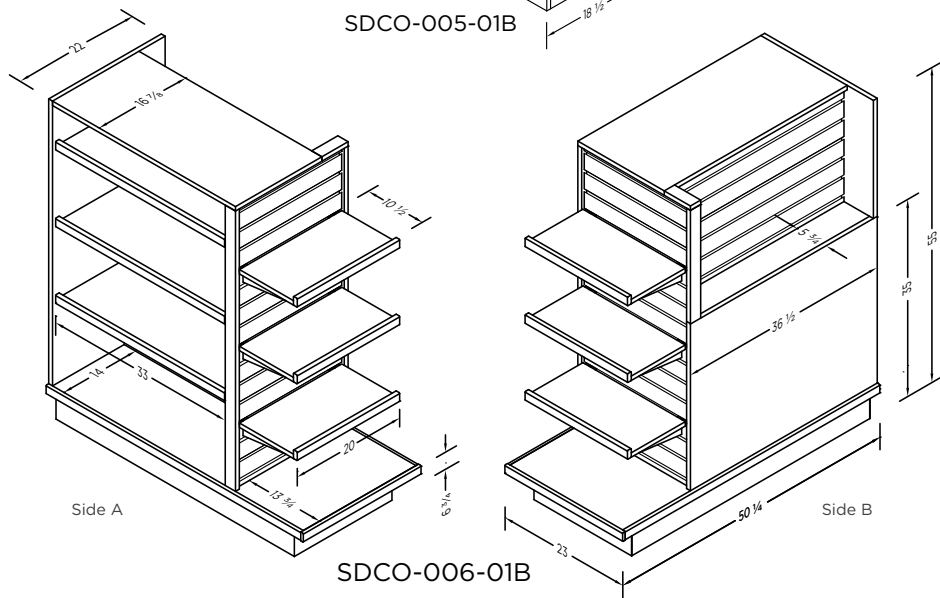
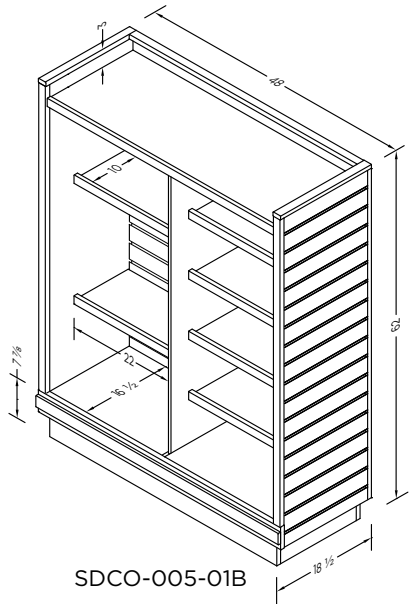
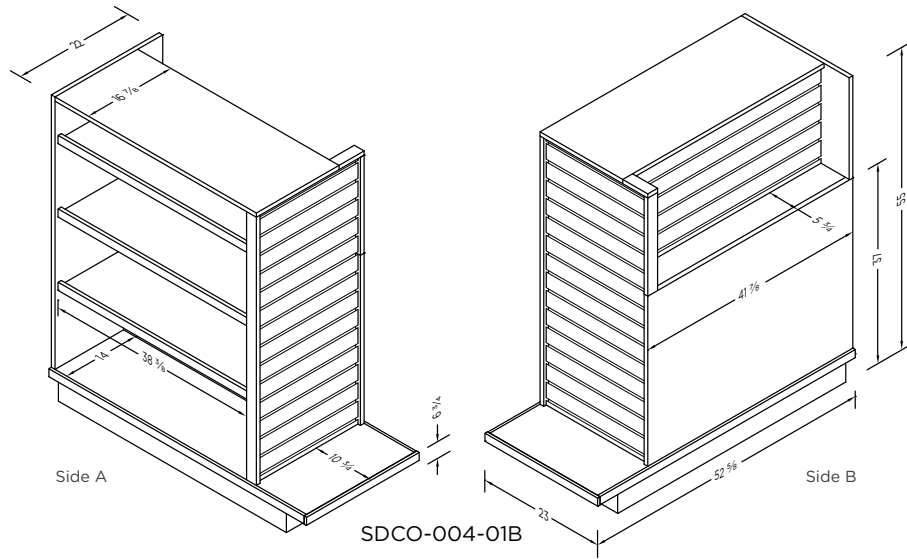



Formica® Laminate

Formica Group provides surfaces that fuse beautiful design with purposeful functionality. Formica® Products provide versatile surfacing solutions that are inspired by and adapt to the way people live, work and play.

Formica® Brand Laminate offers a broader range of looks than ever before. Transform spaces with our modern laminates that are as beautiful as they are durable. Mix and match solids, patterns and finishes.

Product Features:

- Postforming
- Durable and Wear-resistant
- Horizontal and Vertical
- Impact Resistant

Formica® EliteForm

Our innovative Formica® EliteForm surfacing technology redefines the performance attributes of high pressure laminate to deliver a more durable laminate for today’s market. Formica® Laminate with EliteForm features superior scratch resistance over other laminate brands, the ability to postform to a smaller radius with better blister resistance, and more durable, long-lasting surfaces, including the Gloss texture in horizontal applications. EliteForm comes standard on all Formica® Laminates, at no additional cost.

Price Group One: All Colours are matte (-58) finish

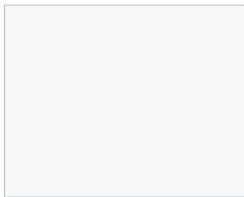

949
White

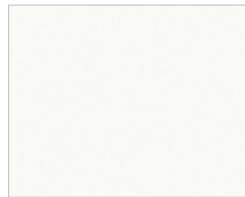

7197
Dover White

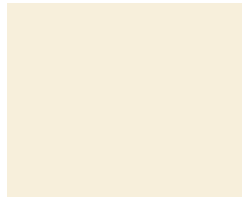

920
Almond

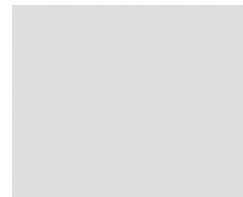

927
Folkstone



961
Fog



845
Spectrum Red



7897
Spectrum Green



914
Marine Blue



2297
Terril

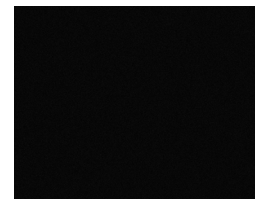

909
Black



6696
Carrara Bianco

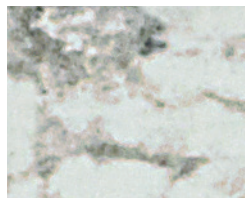

9476
White Ice Granite



9497
Silver Quartzite



7732
Butterum Granite

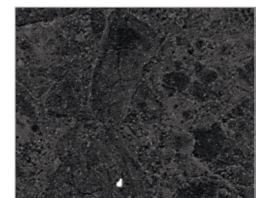

9527
Black Shalestone

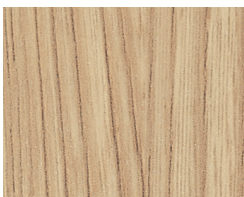

8844
Aged Ash



5883
Pecan Woodline



5884
Chestnut Woodline



9283
Walnut Riftwood



6414
Black Riftwood

Price Group Two: All Colours are matte finish



6997
Pale Brushstroke



6998
Wood Brushstroke



7813
Cardboard Solidz



9319
Stainless



8918
Blackened Steel



9310
White Marble Herringbone



9285
White Twill



6698
Paloma Pear



503
Stone Grafix



8830
Elemental Concrete



8841
White Ash



5785
Ashwood Beige



5795
Camel Elm



8845
Bleached Legno



8916
Blackened Fiberwood



86992
Hardrock Maple



7012
Amber Maple



8677
Scandi Rift Oak



6995
Cherry Walnut



7759
Select Cherry



Formica Canada Inc. is located in St-jean-sur-Richelieu, Quebec, and employs more than 250 people.

Formica Canada is proud to be part of the Well Made Here local purchasing program.

As the inventor of high pressure laminate, Formica Corporation has always worked to provide innovative, high quality products. Efficient use of resources is at our core, and we have taken many steps to improve our environmental footprint - from reusing the water in our presses to incorporating recycled materials into our surfacing products. We are committed to a long-term planning horizon that includes becoming an industry-leading environmental steward.



For larger laminate sample, please visit:
cayugadisplays.com 1-800-839-5536
formica.com 1-800-FORMICA™

PAINTED METAL

- **Standard products in stock**
- **RAL Program** colours not listed are also available upon request
- **Non-RAL Program** colours have long lead times and could affect deliver date

CAYUGA STOCK COLOURS



Cayuga Black



Cayuga White

Cayuga black and white colours come in a textured finish.

Matte finish is available upon request.

RAL STOCK COLOURS



Traffic Blue
Ral 5017

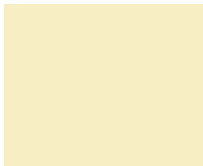

Cream
Ral 9001

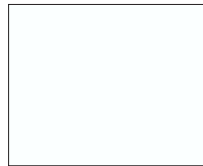

Pure White
Ral 9010



Traffic Orange
Ral 2009



Pebble Grey
Ral 7032



Basalt Grey
Ral 7012



Traffic Grey
Ral 7042



Quartz Grey
Ral 7039



Traffic Red
Ral 3020

WOOD STAINS

CAYUGA STANDARD WOOD GRAINS



Oiled Cherry
Match to Pionite/Panolam
WC421



Wild Cherry
Match to Formica 5904-43



Select Cherry
Match to Formica 7759



Choco Cherry
Match to Panval/Uniboard
207



Natural Maple



Pearwood
Match to Pionite/Panolam
WX031

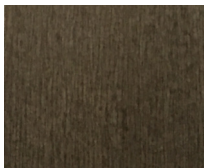

Weathered Wood

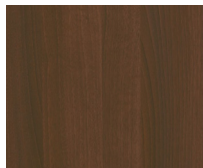

Concerto

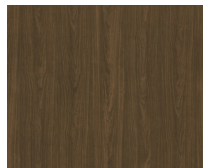

Danish Walnut
Match to Arborite Parliament
Walnut W305

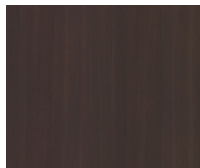

Witchcraft
Match to Pionite/Panolam
WX421



Iron Mountain

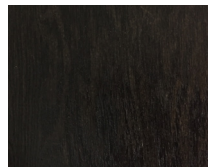

Baloil

Refer to physical swatches for a true representation of colors, above images may appear slightly different than actual samples.

HOW TO ORDER

We'll help you select the right case for your requirements. The steps below will help us to serve you best.

- 1 Choose the showcase that meets your display requirements from the product specification sheets.
- 2 Review the options table found on the specification sheet and make your selections of the options provided.
- 3 Select from the large pallet of colours found on the last five pages of the brochure, or choose a stainless steel, standard black or white for the exterior finish of your showcase.
- 4 E-mail your request for a quote to your Cayuga sales representative or sales@cayugadisplays.com and we will quickly respond to your request. Please include your full contact information in case we have any questions.

Contact the inside sales team

Cayuga Displays

E: sales@cayugadisplays.com

T: 1-800-839-5536

F: 1-905-772-3179



T: 800.839.5536 F: 905.772.3179

E: sales@cayugadisplays.com

A: 88 Talbot St E, PO Box 130
Cayuga, ON N0A 1E0

