



# FLORAL

COLLECTION

 **Cayuga** DISPLAYS













# DEPARTMENT: FLORAL

**The floral department is a beautiful opportunity to enhance the fresh, vital impression of your overall store. We help you make the most of your stock, in its presentation and preservation!**

The highly fluctuating nature of the floral department inventory means display units need to be versatile. We offer a number of mobile-friendly shelves, tables and cases to move easily out of the way when not needed and to blend seamlessly with the fixed components.

*"I have worked with various fixture and millwork suppliers and I must say that Cayuga has provided me with the best product and service of them all."*

Sharon Young, McGinnis Sisters  
Special Food Stores.  
Pittsburgh, PA



# Table of Contents

Things To Consider	6
Refrigerated FLoral Display	
Three-Level Upright Self-Service Display - 54”H	8
Floral Steps	
Straight - 2 Step	12
Outside Cornter - 2 Step	13
Straight - 3 Step	14
Outside Cornter - 3 Step	15
Wrapping Station	
Floral Carts	16
Nesting Table Set	
Galvanized Top - Large	17
Galvanized Top - Small	18
Pedestal Tables	
Galvanized Top w/ Removable Insert	19
Finishes	
Laminate	20
Painted Metal	22
Wood Stains	23
How to Order	24



# THINGS TO CONSIDER

Showcases are designed to display your refrigerated products at 38-41°F (4-5°C). Showcases are designed to perform correctly when placed in environmental conditions of maximum 75°F (23°C) and 55% relative humidity.

When selecting a showcase and placing it in your store environment, you need to consider the following:

## 1 Consider nearby doorways

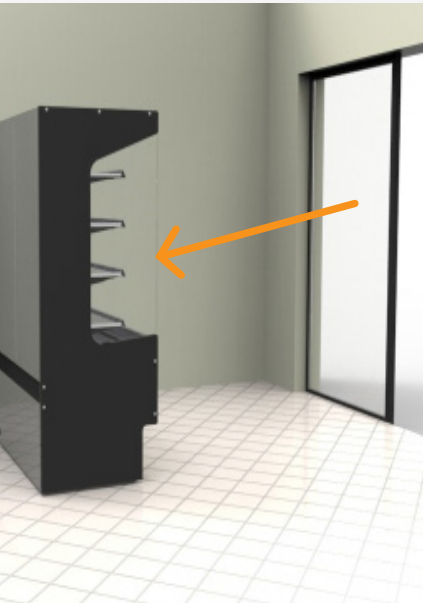

A location near a doorway will affect the airflow and holding temperature of open and closed showcases.

## 2 Consider nearby windows



Direct sunlight will affect the holding temperature of open or closed showcases.

## 3 Consider nearby vent sources and fans



HVAC ceiling vents and ceiling fans will affect the airflow of open showcases and could create condensation on the glass of closed showcases.

## 4 Ensure your display is level and plumb



Ensure your showcase is plumb and level to allow for proper drainage of condensation water.

**Please note:** These are critical points to ensure the best results for your space - and the best return on your investment!



## Maintenance

Your showcase will work at its peak performance with regular maintenance. An owners' manual with maintenance instructions is included or you can also check out our online maintenance video.



Watch our maintenance video at [cayugadisplays.com/maintenance](http://cayugadisplays.com/maintenance)



### 5 Leave appropriate space behind display

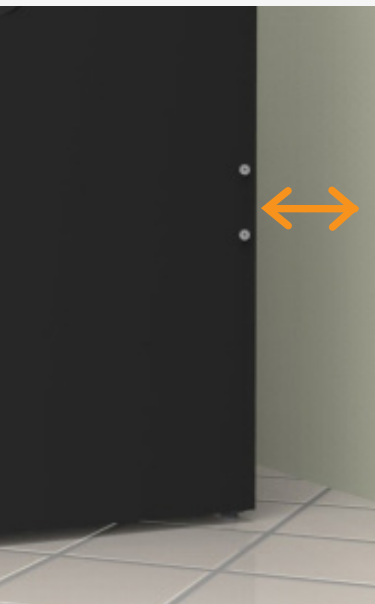

A 6" space is required behind any showcase that is against a wall or has a rear obstruction.

### 6 Clean your displays



Use the included brush to regularly wipe away dust. Too much dust will not allow the refrigeration to work properly and could result in damage.

### 7 NO warm product in case



Refrigerated displays are designed to KEEP COLD PRODUCT COLD - they are not designed to bring warm product down to a cold temperature. For food safety it is always imperative that warm product be properly chilled (using a blast chiller or cold room) prior to storing in the refrigerated display case.

### 8 Noise



Self-contained cases have compressor motors and fans and these will make noise, just as your household refrigerator makes noise. Keeping your showcase serviced and clean will help keep the noise level under control.



# THREE-LEVEL UPRIGHT SELF-SERVICE FLORAL DISPLAY - 54"H

 REFRIGERATED



Standard features shown



Custom options available, refer to options schedule on next page.

MODEL	LENGTH
FLP-MRO-24-54	26"
FLP-MRO-38-54	40 1/4"
FLP-MRO-48-54	49 7/8"
FLP-MRO-57-54	59 3/8"
FLP-MRO-76-54	78 1/2"
FLP-MRO-96-54	97 5/8"

## FEATURES:

- Many exterior finish options available: powdercoat paint, brushed stainless steel, laminates and natural wood finishes
- Textured powdercoat black interior
- Other custom options are offered. Refer to the options schedule on the next page
- Designed to maintain the critical temperature of the products within the display at a range of 38-41°F (3-5°C) with an ambient atmosphere of 75°F (24°C)/55% humidity
- ETL electrical certification and NSF 7 standards
- New R-513A (non-ozone depleting, low global warming potential) refrigerant used in the self-contained refrigeration system
- The refrigeration system is designed to pull fresh air through a front base vent and exhaust heated air through an integrated vent at the back of the display
- Remote refrigeration available. Contact Cayuga Displays for details

Note: Information and specifications may change due to engineering improvements.

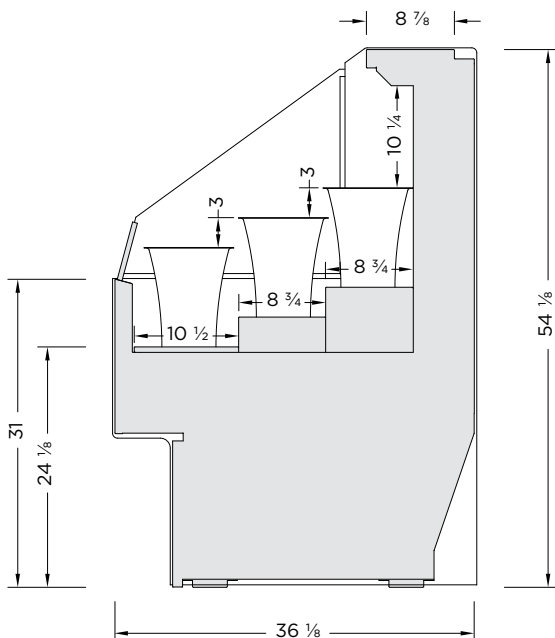





# THREE-LEVEL UPRIGHT SELF-SERVICE FLORAL DISPLAY - 54" H

 REFRIGERATED

TECHNICAL SPECS				
MODEL	LENGTH	VOLTS	AMPS	NEMA PLUG
FLP-MRO-24-54	26"	115	11.7	5-15P
FLP-MRO-38-54	40 ¼"	115	11.7	5-15P
FLP-MRO-48-54	49 ⅞"	115	11.7	5-15P
FLP-MRO-57-54	59 ⅜"	115/230	8.7	L14-20P
FLP-MRO-76-54	78 ½"	115/230	12.4	L14-20P
FLP-MRO-96-54	97 ⅝"	115/230	12.4	L14-20P

## STANDARD FEATURES:

- Textured powdercoat black interior
- Black laminate exterior finish
- Solid End Panels with black interior finish
- The refrigeration system is designed to pull fresh air through a front base vent and exhaust heated air through an integrated vent at the back of the display

## CUSTOM FEATURES:

EXTERIOR FINISHES	
Formica laminate finish: _____	
Other laminate finish (specify): _____	
Customer laminate choices	
Brushed Stainless Steel	
Oak Veneer Plywood	
- Vertical grain direction	
- Horizontal grain direction	
Birch/Maple Veneer Plywood	
- Vertical grain direction	
- Horizontal grain direction	
Clear finish applied to veneer	
Stain finish Choice: _____	
1" black McCue impact bumper strip applied to the front of the display	
Other McCue impact bumper strip colors available upon request	

## END PANELS

Interior laminate the same as exterior	
Tempered glass end panels	
1" black McCue impact bumper strip applied to the front of the display	
Other McCue impact bumper strip colors available upon request	

## MISCELLANEOUS

Heavy duty lockable casters	
-----------------------------	--

## ADDITIONAL FEATURES:

- Designed to maintain the critical temperature of the products within the display at a range of 38-41°F (3-5°C) with an ambient atmosphere of 75°F (24°C)/55% humidity. Designed for holding pre-chilled product only
- Hot gas condensate evaporation system (most units)
- ETL listed and Sanitation certified to NSF-7
- 1 year parts and labor warranty



# THREE-LEVEL UPRIGHT SELF-SERVICE FLORAL DISPLAY - 54”H

## STANDARD FEATURES SHOWN

FLP-MRO-24-54



FINISHES:  
POWDERCOAT,  
TEXTURED BLACK

## CUSTOM FEATURES SHOWN



FINISHES:  
LAMINATE,  
SEASONED PLANKED ELM (8908)

FLP-MRO-38-54



FINISHES:  
POWDERCOAT,  
TEXTURED BLACK



FINISHES:  
LAMINATE,  
CINDER WOOD (9643)

FLP-MRO-48-54



FINISHES:  
POWDERCOAT,  
TEXTURED BLACK

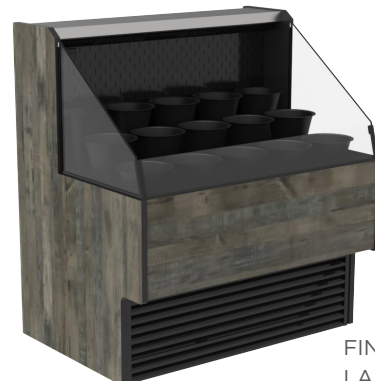

FINISHES:  
LAMINATE,  
SEASONED PLANKED ELM (8908)



# THREE-LEVEL UPRIGHT SELF-SERVICE FLORAL DISPLAY - 54”H

## STANDARD FEATURES SHOWN

## CUSTOM FEATURES SHOWN

### FLP-MRO-57-54



FINISHES:  
POWDERCOAT,  
TEXTURED BLACK



FINISHES:  
LAMINATE,  
CINDER WOOD (9643)

### FLP-MRO-76-54



FINISHES:  
POWDERCOAT,  
TEXTURED BLACK



FINISHES:  
LAMINATE,  
SEASONED PLANKED ELM (8908)

### FLP-MRO-96-54

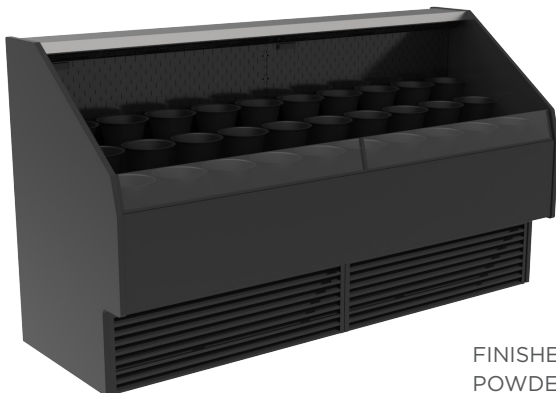

FINISHES:  
POWDERCOAT,  
TEXTURED BLACK



FINISHES:  
LAMINATE,  
CINDER WOOD (9643)

# FLORAL STEPS

## STRAIGHT - 2 STEP



Clear finish shown



Danish Walnut finish shown. Other finishes available - see chart.

MODEL	DESCRIPTION	LENGTH	DEPTH	HEIGHT
ST2S-006-01C	Floral Step - 48"	47 ½"	24"	29"
ST2S-006-02C	Floral Step - 36"	35 ½"	24"	29"

**FEATURES:**

- Birch/maple plywood & galvanized metal step top
- Levelers
- ABS bumper

**OPTIONS:**

- Refer to Wood Stains Finishes

Note: Information and specifications may change due to engineering improvements.

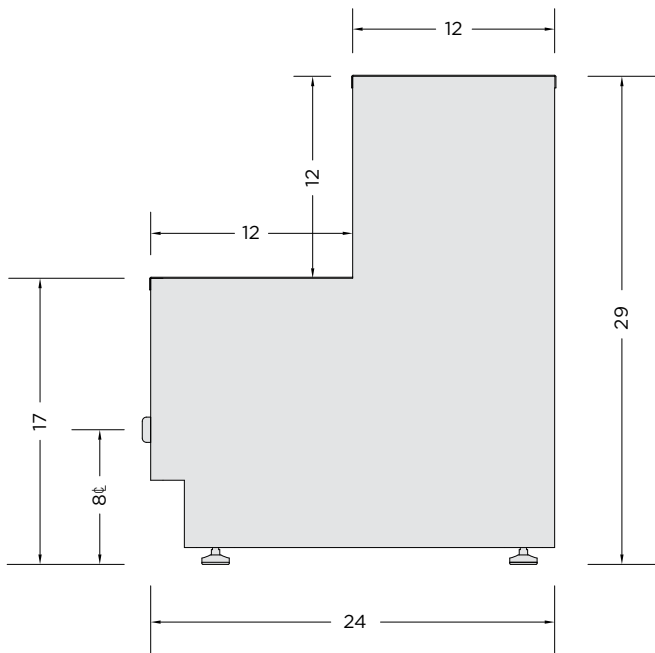

ST2S-006-01C (47 ½"L) & ST2S-006-02C (35 ½"L)

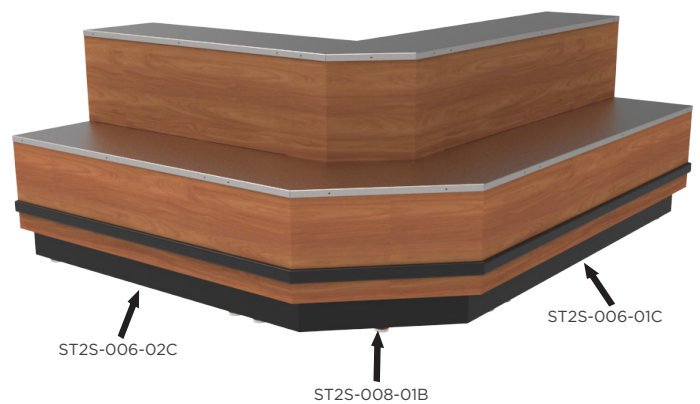



# FLORAL STEPS

## OUTSIDE CORNER - 2 STEP

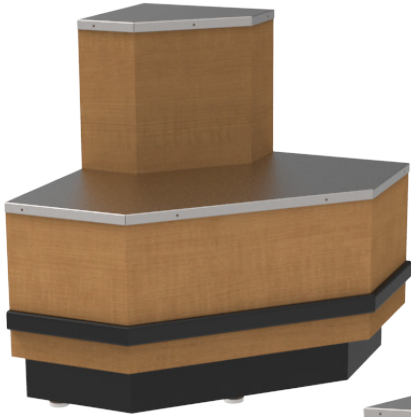

Clear finish shown

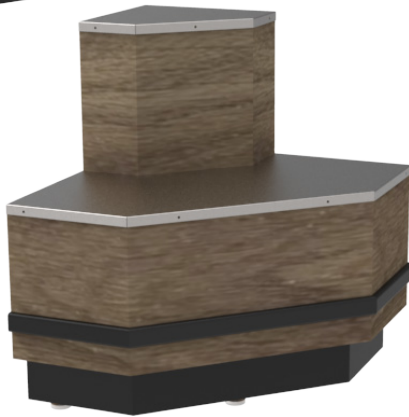

Weathered Wood finish shown. Other finishes available - see chart.

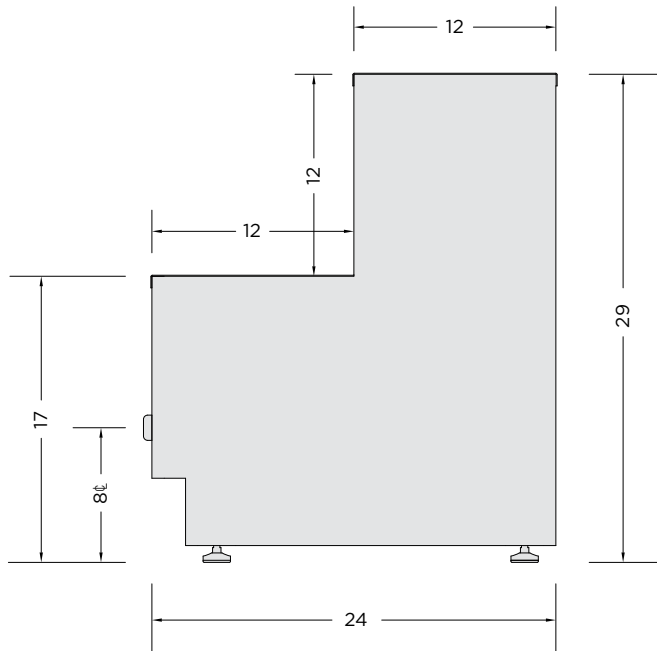

ST2S-008-01B

MODEL	DESCRIPTION	LENGTH	DEPTH	HEIGHT
ST2S-008-01B	Floral Step Outside Corner	24"	24"	29"

### FEATURES:

- Birch/maple plywood & galvanized metal step top
- Levelers
- ABS bumper

### OPTIONS:

- Refer to Wood Stains Finishes

Note: Information and specifications may change due to engineering improvements.

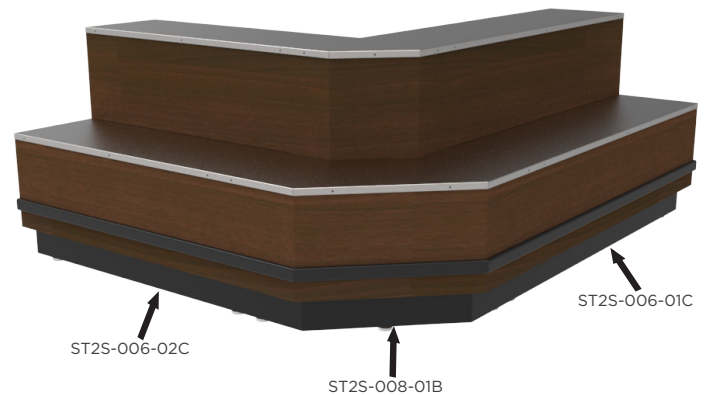

# FLORAL STEPS

## STRAIGHT - 3 STEP



MODEL	DESCRIPTION	LENGTH	DEPTH	HEIGHT
ST3S-006-01C	Floral Step - 48"	47 1/2"	36"	41"
ST3S-006-02C	Floral Step - 36"	35 1/2"	36"	41"

### FEATURES:

- Birch/maple plywood & galvanized metal step top
- Levelers
- ABS bumper

### OPTIONS:

- Refer to Wood Stains Finishes

Note: Information and specifications may change due to engineering improvements.

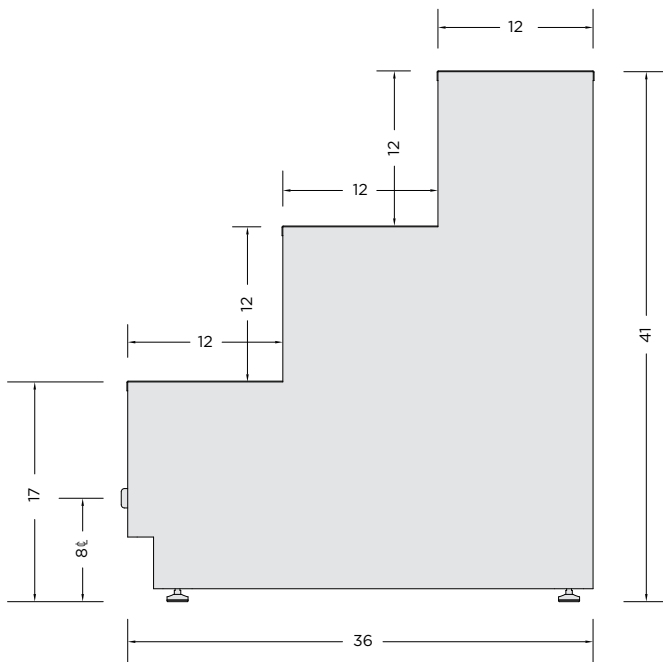

ST3S-006-01C (47 1/2"L) &  
ST3S-006-02C (35 1/2"L)

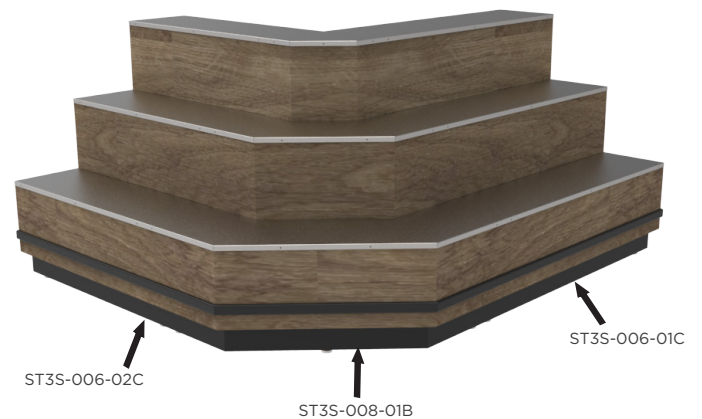



# FLORAL STEPS

## OUTSIDE CORNER - 3 STEP

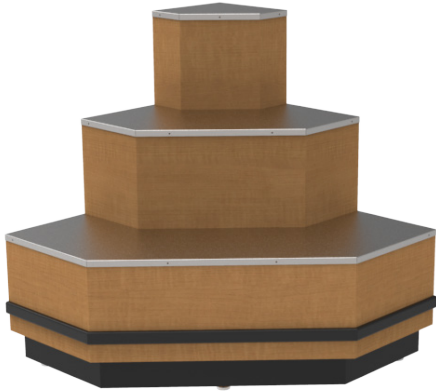

Clear finish shown



Concerto finish shown. Other finishes available - see chart.

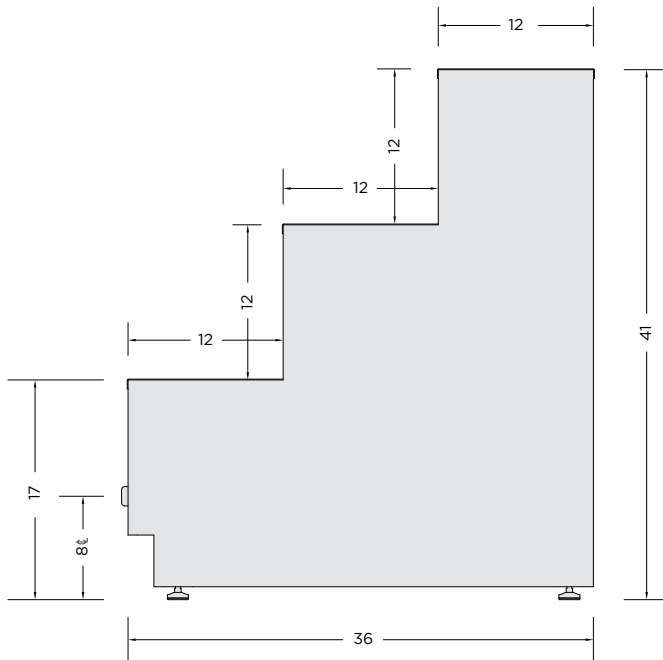

ST3S-008-01B

MODEL	DESCRIPTION	LENGTH	DEPTH	HEIGHT
ST3S-008-01B	Floral Step Outside Corner	36"	36"	41"

### FEATURES:

- Birch/maple plywood & galvanized metal step top
- Levelers
- ABS bumper

### OPTIONS:

- Refer to Wood Stains Finishes

Note: Information and specifications may change due to engineering improvements.

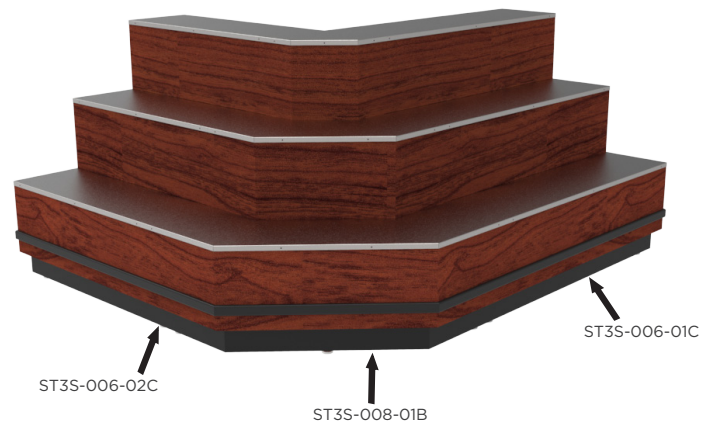

# WRAPPING STATION FLORAL CARTS

Clear finish shown



CRWS-001-01B

CRWS-002-01C



Weathered Wood finish shown. Other finishes available - see chart.

MODEL	DESCRIPTION	LENGTH	DEPTH	HEIGHT
CRWS-001-01B	Floral Wrapping Cart	37"	23"	36"
CRWS-002-01C	Floral Wrapping Cart w/ Bag holder	37"	24"	53"

### FEATURES:

- Birch/maple plywood & melamine drawers construction w/ laminated counter top
- Heavy duty casters (2 locking)
- Two fixed shelves & pull out lower shelf
- CRWS-002-01C
  - Metal dispenser designed to hold floral wrap
- ABS bumper

### OPTIONS:

- Refer to Wood Stains Finishes

Note: Information and specifications may change due to engineering improvements.

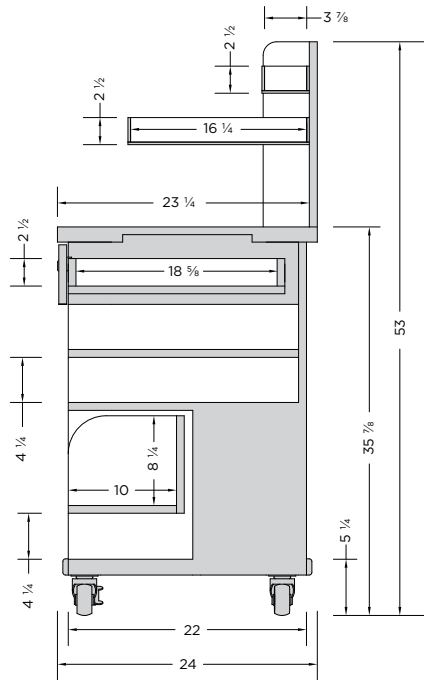

CRWS-002-01C

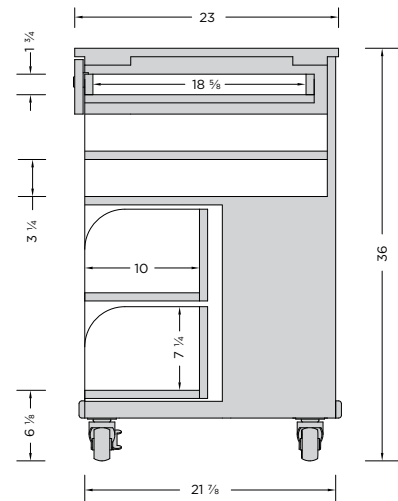

CRWS-001-01B



# NESTING TABLE SET

## GALVANIZED TOP - LARGE



Clear finish shown



Oiled Cherry finish shown. Other finishes available - see chart.

MODEL	DESCRIPTION	LENGTH	DEPTH	HEIGHT
TBST-016-01F	3 Piece Nesting Table Set - Large			
TBFL-020-01E	Nesting Table - Large	47 ½"	18"	30"
TBFL-021-01E	Nesting Table - Medium	38 ½"	18"	25"
TBFL-022-01E	Nesting Table - Small	29 ½"	18"	20"

### FEATURES:

- Birch/maple plywood and solid maple construct with galvanized tops
- Leg caps
- Tack glides

### OPTIONS:

- Bumper, corner guards
- Refer to Wood Stains Finishes

Note: Information and specifications may change due to engineering improvements.

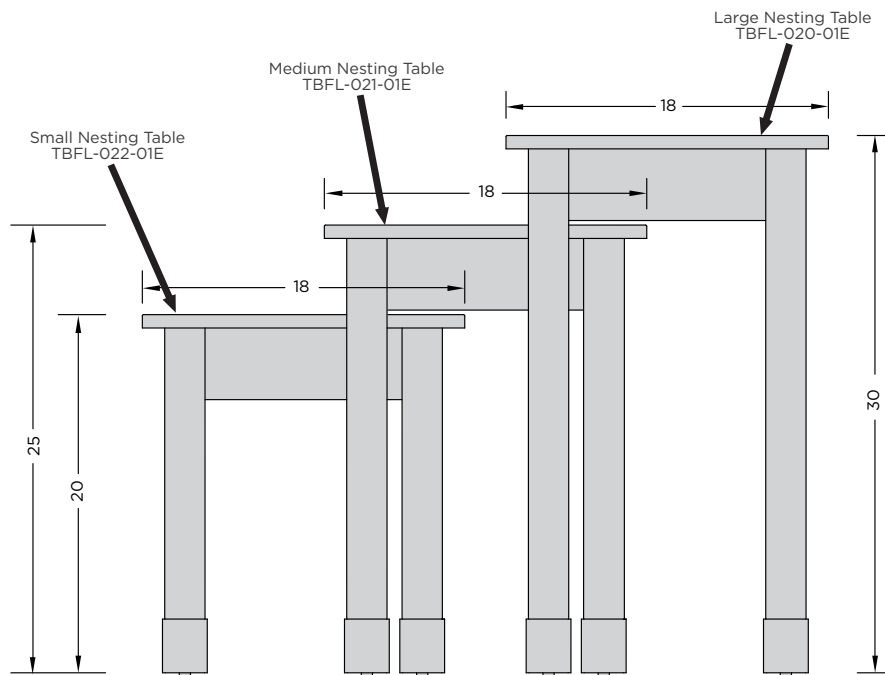

TBST-016-01F

# NESTING TABLE SET

## GALVANIZED TOP - SMALL



Clear finish shown



Concerto finish shown. Other finishes available - see chart.

MODEL	DESCRIPTION	LENGTH	DEPTH	HEIGHT
TBST-016-01E	3 Piece Nesting Table Set - Small			
TBFL-017-01E	Nesting Table - Large	47 ½"	14"	30"
TBFL-018-01E	Nesting Table - Medium	38 ½"	14"	25"
TBFL-019-01E	Nesting Table - Small	29 ½"	14"	20"

### FEATURES:

- Birch/maple plywood and solid maple construct with galvanized tops
- Leg caps
- Tack glides

### OPTIONS:

- Bumper, corner guards
- Refer to Wood Stains Finishes

Note: Information and specifications may change due to engineering improvements.

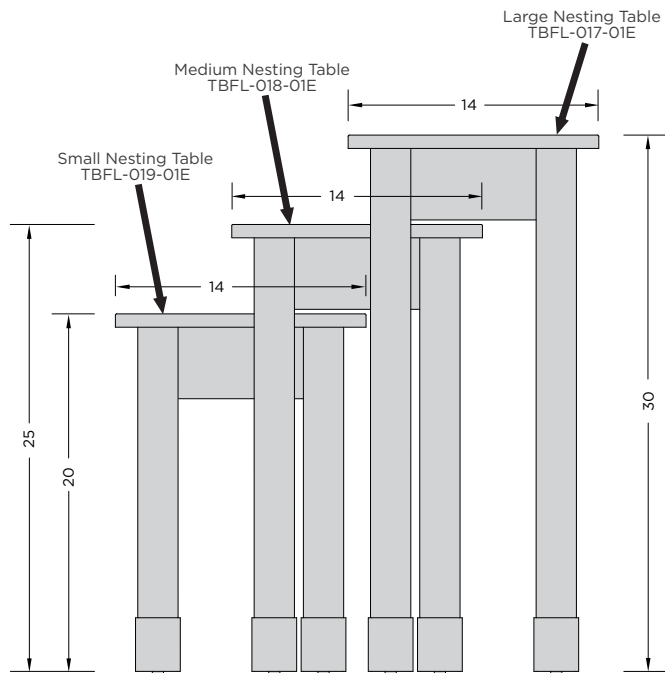

TBST-016-01E



# PEDESTAL TABLES

## GALVANIZED TOP WITH REMOVABLE INSERT

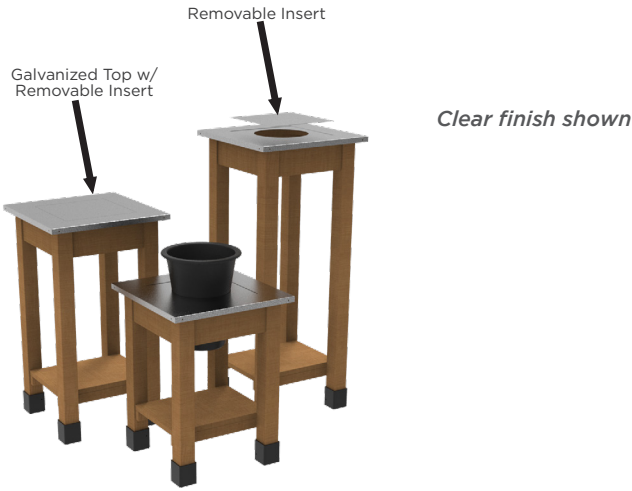

MODEL	DESCRIPTION	LENGTH	DEPTH	HEIGHT
TBFL-026-01C	Pedestal Table - Short	18"	18"	24 1/2"
TBFL-027-01C	Pedestal Table - Medium	18"	18"	32 1/2"
TBFL-028-01C	Pedestal Table - Tall	18"	18"	42 1/2"

### FEATURES:

- Birch/maple plywood and solid maple construct with galvanized tops & insert
- Leg caps
- Tack glides
- Removable insert to accommodate pots

### OPTIONS:

- Bumper, corner guards
- Refer to Wood Stains Finishes

**\*\*Flower pots not supplied\*\***

Note: Information and specifications may change due to engineering improvements.

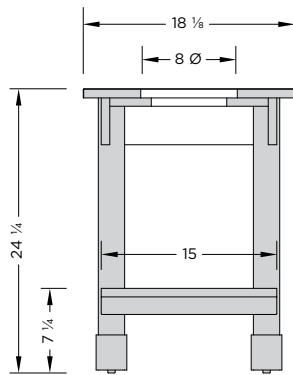

TBFL-026-01C

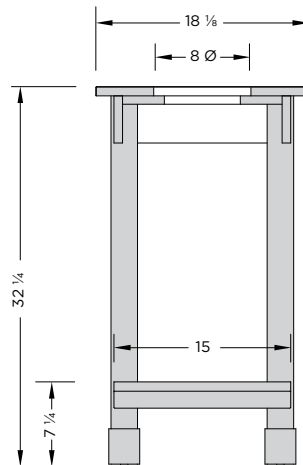

TBFL-027-01C

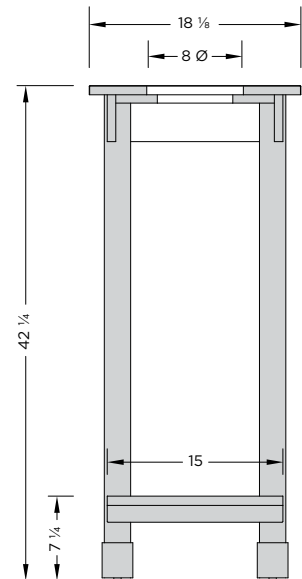

TBFL-028-01C



### Formica® Laminate

Formica Group provides surfaces that fuse beautiful design with purposeful functionality. Formica® Products provide versatile surfacing solutions that are inspired by and adapt to the way people live, work and play.

Formica® Brand Laminate offers a broader range of looks than ever before. Transform spaces with our modern laminates that are as beautiful as they are durable. Mix and match solids, patterns and finishes.

#### Product Features:

- Postforming
- Durable and Wear-resistant
- Horizontal and Vertical
- Impact Resistant

### Formica® EliteForm

Our innovative Formica® EliteForm surfacing technology redefines the performance attributes of high pressure laminate to deliver a more durable laminate for today’s market. Formica® Laminate with EliteForm features superior scratch resistance over other laminate brands, the ability to postform to a smaller radius with better blister resistance, and more durable, long-lasting surfaces, including the Gloss texture in horizontal applications. EliteForm comes standard on all Formica® Laminates, at no additional cost.

#### Price Group One: All Colours are matte (-58) finish

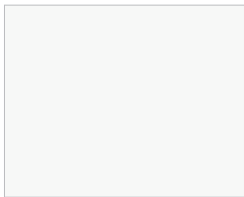

**949**  
White

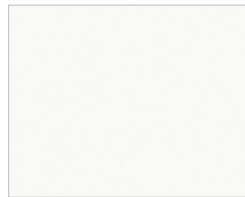

**7197**  
Dover White

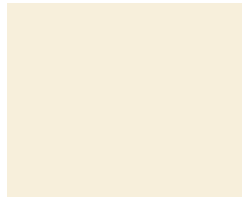

**920**  
Almond

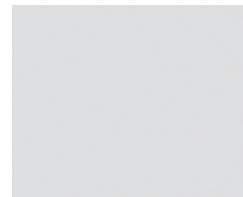

**927**  
Folkstone



**961**  
Fog



**845**  
Spectrum Red



**7897**  
Spectrum Green



**914**  
Marine Blue



**2297**  
Terril

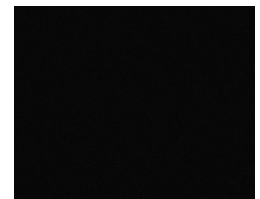

**909**  
Black



**6696**  
Carrara Bianco

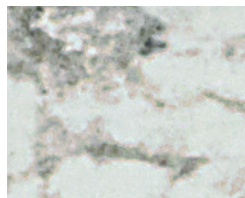

**9476**  
White Ice Granite



**9497**  
Silver Quartzite



**7732**  
Butterum Granite

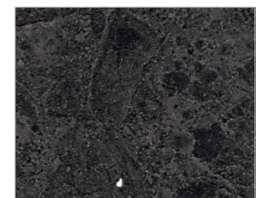

**9527**  
Black Shalestone

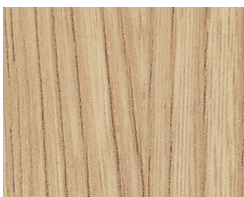

**8844**  
Aged Ash



**5883**  
Pecan Woodline



**5884**  
Chestnut Woodline



**9283**  
Walnut Riftwood



**6414**  
Black Riftwood



**Price Group Two: All Colours are matte finish**



**6997**  
Pale Brushstroke



**6998**  
Wood Brushstroke



**7813**  
Cardboard Solidz



**9319**  
Stainless



**8918**  
Blackened Steel



**9310**  
White Marble Herringbone



**9285**  
White Twill



**6698**  
Paloma Pear



**503**  
Stone Grafix



**8830**  
Elemental Concrete



**8841**  
White Ash



**5785**  
Ashwood Beige



**5795**  
Camel Elm



**8845**  
Bleached Legno



**8916**  
Blackened Fiberwood



**86992**  
Hardrock Maple



**7012**  
Amber Maple



**8677**  
Scandi Rift Oak



**6995**  
Cherry Walnut



**7759**  
Select Cherry



Formica Canada Inc. is located in St-jean-sur-Richelieu, Quebec, and employs more than 250 people.

Formica Canada is proud to be part of the Well Made Here local purchasing program.

As the inventor of high pressure laminate, Formica Corporation has always worked to provide innovative, high quality products. Efficient use of resources is at our core, and we have taken many steps to improve our environmental footprint - from reusing the water in our presses to incorporating recycled materials into our surfacing products. We are committed to a long-term planning horizon that includes becoming an industry-leading environmental steward.



**For larger laminate sample, please visit:**  
**cayugadisplays.com 1-800-839-5536**  
**formica.com 1-800-FORMICA™**

# PAINTED METAL

- **Standard products in stock**
- **RAL Program** colours not listed are also available upon request
- **Non-RAL Program** colours have long lead times and could affect deliver date

## CAYUGA STOCK COLOURS



Cayuga Black



Cayuga White

Cayuga black and white colours come in a textured finish.

Matte finish is available upon request.

## RAL STOCK COLOURS



Traffic Blue  
Ral 5017



Cream  
Ral 9001

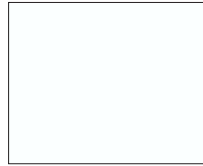

Pure White  
Ral 9010



Traffic Orange  
Ral 2009



Pebble Grey  
Ral 7032



Basalt Grey  
Ral 7012



Traffic Grey  
Ral 7042



Quartz Grey  
Ral 7039



Traffic Red  
Ral 3020

# WOOD STAINS

## CAYUGA STANDARD WOOD GRAINS

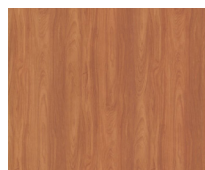

Oiled Cherry  
Match to Pionite/Panolam  
WC421

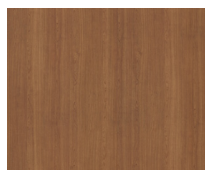

Wild Cherry  
Match to Formica 5904-43

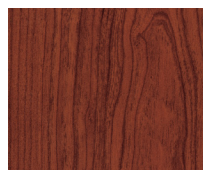

Select Cherry  
Match to Formica 7759

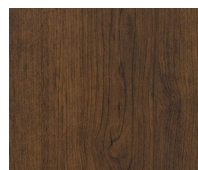

Choco Cherry  
Match to Panval/Uniboard  
207



Natural Maple

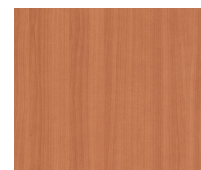

Pearwood  
Match to Pionite/Panolam  
WX031

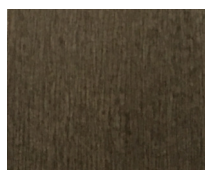

Weathered Wood

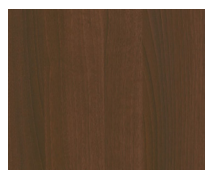

Concerto

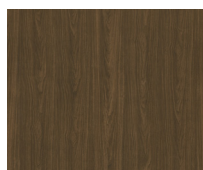

Danish Walnut  
Match to Arborite Parliament  
Walnut W305

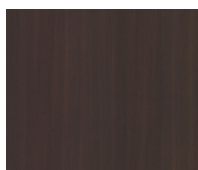

Witchcraft  
Match to Pionite/Panolam  
WX421



Iron Mountain

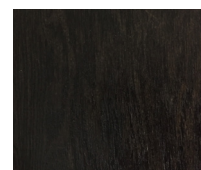

Baloil

\*Refer to physical swatches for a true representation of colors, above images may appear slightly different than actual samples.\*



# HOW TO ORDER

We'll help you select the right case for your requirements. The steps below will help us to serve you best.

- 1 Choose the showcase that meets your display requirements from the product specification sheets.
- 2 Review the options table found on the specification sheet and make your selections of the options provided.
- 3 Select from the large pallet of colours found on the last five pages of the brochure, or choose a stainless steel, standard black or white for the exterior finish of your showcase.
- 4 E-mail your request for a quote to your Cayuga sales representative or [sales@cayugadisplays.com](mailto:sales@cayugadisplays.com) and we will quickly respond to your request. Please include your full contact information in case we have any questions.

## Contact the inside sales team

### Cayuga Displays

E: [sales@cayugadisplays.com](mailto:sales@cayugadisplays.com)

T: 1-800-839-5536

F: 1-905-772-3179



**T: 800.839.5536 F: 905.772.3179**

**E: [sales@cayugadisplays.com](mailto:sales@cayugadisplays.com)**

**A: 88 Talbot St E, PO Box 130  
Cayuga, ON NOA 1E0**